Mathematics**SECTION 1 (Maximum Marks: 12)**

- This section contains **FOUR (04)** questions.
- Each question has **FOUR** options (A), (B), (C) and (D). **ONLY ONE** of these four options is the correct answer.
- For each question, choose the option corresponding to the correct answer.
- Answer to each question will be evaluated according to the following marking scheme:
Full Marks : +3 If **ONLY** the correct option is chosen;
Zero Marks : 0 If none of the options is chosen (i.e. the question is unanswered);
Negative Marks : -1 In all other cases.

Q.1 Let $f : [1, \infty) \rightarrow \mathbb{R}$ be a differentiable function such that $f(1) = \frac{1}{3}$ and

$3 \int_1^x f(t) dt = x f(x) - \frac{x^3}{3}$, $x \in [1, \infty)$. Let e denote the base of the natural logarithm. Then the value of $f(e)$ is

- (A) $\frac{e^2 + 4}{3}$ (B) $\frac{\log_e 4 + e}{3}$ (C) $\frac{4e^2}{3}$ (D) $\frac{e^2 - 4}{3}$

Q.2 Consider an experiment of tossing a coin repeatedly until the outcomes of two consecutive tosses are same. If the probability of a random toss resulting in head is $\frac{1}{3}$, then the probability that the experiment stops with head is

- (A) $\frac{1}{3}$ (B) $\frac{5}{21}$ (C) $\frac{4}{21}$ (D) $\frac{2}{7}$

Q.3 For any $y \in \mathbb{R}$, let $\cot^{-1}(y) \in (0, \pi)$ and $\tan^{-1}(y) \in \left(-\frac{\pi}{2}, \frac{\pi}{2}\right)$. Then the sum of all the solutions of the equation $\tan^{-1}\left(\frac{6y}{9-y^2}\right) + \cot^{-1}\left(\frac{9-y^2}{6y}\right) = \frac{2\pi}{3}$ for $0 < |y| < 3$, is equal to

- (A) $2\sqrt{3} - 3$ (B) $3 - 2\sqrt{3}$ (C) $4\sqrt{3} - 6$ (D) $6 - 4\sqrt{3}$
-

Q.4 Let the position vectors of the points P, Q, R and S be $\vec{a} = \hat{i} + 2\hat{j} - 5\hat{k}$, $\vec{b} = 3\hat{i} + 6\hat{j} + 3\hat{k}$,
 $\vec{c} = \frac{17}{5}\hat{i} + \frac{16}{5}\hat{j} + 7\hat{k}$ and $\vec{d} = 2\hat{i} + \hat{j} + \hat{k}$, respectively. Then which of the following statements is true?

(A) The points P, Q, R and S are **NOT** coplanar

(B) $\frac{\vec{b} + 2\vec{d}}{3}$ is the position vector of a point which divides PR internally in the ratio $5 : 4$

(C) $\frac{\vec{b} + 2\vec{d}}{3}$ is the position vector of a point which divides PR externally in the ratio $5 : 4$

(D) The square of the magnitude of the vector $\vec{b} \times \vec{d}$ is 95

SECTION 2 (Maximum Marks: 12)

- This section contains **THREE (03)** questions.
- Each question has **FOUR** options (A), (B), (C) and (D). **ONE OR MORE THAN ONE** of these four option(s) is (are) correct answer(s).
- For each question, choose the option(s) corresponding to (all) the correct answer(s).
- Answer to each question will be evaluated according to the following marking scheme:
 - Full Marks* : +4 **ONLY** if (all) the correct option(s) is(are) chosen;
 - Partial Marks* : +3 If all the four options are correct but **ONLY** three options are chosen;
 - Partial Marks* : +2 If three or more options are correct but **ONLY** two options are chosen, both of which are correct;
 - Partial Marks* : +1 If two or more options are correct but **ONLY** one option is chosen and it is a correct option;
 - Zero Marks* : 0 If unanswered;
 - Negative Marks* : -2 In all other cases.
- For example, in a question, if (A), (B) and (D) are the **ONLY** three options corresponding to correct answers, then
 - choosing **ONLY** (A), (B) and (D) will get +4 marks;
 - choosing **ONLY** (A) and (B) will get +2 marks;
 - choosing **ONLY** (A) and (D) will get +2 marks;
 - choosing **ONLY** (B) and (D) will get +2 marks;
 - choosing **ONLY** (A) will get +1 mark;
 - choosing **ONLY** (B) will get +1 mark;
 - choosing **ONLY** (D) will get +1 mark;
 - choosing no option(s) (i.e. the question is unanswered) will get 0 marks and
 - choosing any other option(s) will get -2 marks.

Q.5 Let $M = (a_{ij})$, $i, j \in \{1, 2, 3\}$, be the 3×3 matrix such that $a_{ij} = 1$ if $j+1$ is divisible by i , otherwise $a_{ij} = 0$. Then which of the following statements is(are) true?

(A) M is invertible

(B) There exists a nonzero column matrix $\begin{pmatrix} a_1 \\ a_2 \\ a_3 \end{pmatrix}$ such that $M \begin{pmatrix} a_1 \\ a_2 \\ a_3 \end{pmatrix} = \begin{pmatrix} -a_1 \\ -a_2 \\ -a_3 \end{pmatrix}$

(C) The set $\{X \in \mathbb{R}^3 : MX = \mathbf{0}\} \neq \{\mathbf{0}\}$, where $\mathbf{0} = \begin{pmatrix} 0 \\ 0 \\ 0 \end{pmatrix}$

(D) The matrix $(M - 2I)$ is invertible, where I is the 3×3 identity matrix

Q.6

Let $f : (0,1) \rightarrow \mathbb{R}$ be the function defined as $f(x) = [4x] \left(x - \frac{1}{4}\right)^2 \left(x - \frac{1}{2}\right)$, where $[x]$ denotes the greatest integer less than or equal to x . Then which of the following statements is(are) true?

- (A) The function f is discontinuous exactly at one point in $(0,1)$
- (B) There is exactly one point in $(0,1)$ at which the function f is continuous but **NOT** differentiable
- (C) The function f is **NOT** differentiable at more than three points in $(0,1)$
- (D) The minimum value of the function f is $-\frac{1}{512}$

Q.7

Let S be the set of all twice differentiable functions f from \mathbb{R} to \mathbb{R} such that $\frac{d^2 f}{dx^2}(x) > 0$ for all $x \in (-1,1)$. For $f \in S$, let X_f be the number of points $x \in (-1,1)$ for which $f(x) = x$. Then which of the following statements is(are) true?

- (A) There exists a function $f \in S$ such that $X_f = 0$
 - (B) For every function $f \in S$, we have $X_f \leq 2$
 - (C) There exists a function $f \in S$ such that $X_f = 2$
 - (D) There does **NOT** exist any function f in S such that $X_f = 1$
-

SECTION 3 (Maximum Marks: 24)

- This section contains **SIX (06)** questions.
- The answer to each question is a **NON-NEGATIVE INTEGER**.
- For each question, enter the correct integer corresponding to the answer using the mouse and the on-screen virtual numeric keypad in the place designated to enter the answer.
- Answer to each question will be evaluated according to the following marking scheme:
Full Marks : +4 If **ONLY** the correct integer is entered;
Zero Marks : 0 In all other cases.

Q.8 For $x \in \mathbb{R}$, let $\tan^{-1}(x) \in \left(-\frac{\pi}{2}, \frac{\pi}{2}\right)$. Then the minimum value of the function

$$f: \mathbb{R} \rightarrow \mathbb{R} \text{ defined by } f(x) = \int_0^{x \tan^{-1} x} \frac{e^{(t-\cos t)}}{1+t^{2023}} dt \text{ is}$$

Q.9 For $x \in \mathbb{R}$, let $y(x)$ be a solution of the differential equation

$$(x^2 - 5) \frac{dy}{dx} - 2xy = -2x(x^2 - 5)^2 \text{ such that } y(2) = 7.$$

Then the maximum value of the function $y(x)$ is

Q.10 Let X be the set of all five digit numbers formed using 1,2,2,2,4,4,0. For example, 22240 is in X while 02244 and 44422 are not in X . Suppose that each element of X has an equal chance of being chosen. Let p be the conditional probability that an element chosen at random is a multiple of 20 given that it is a multiple of 5. Then the value of $38p$ is equal to

Q.11 Let $A_1, A_2, A_3, \dots, A_8$ be the vertices of a regular octagon that lie on a circle of radius 2. Let P be a point on the circle and let PA_i denote the distance between the points P and A_i for $i = 1, 2, \dots, 8$. If P varies over the circle, then the maximum value of the product $PA_1 \cdot PA_2 \cdots PA_8$, is

Q.12 Let $R = \left\{ \begin{pmatrix} a & 3 & b \\ c & 2 & d \\ 0 & 5 & 0 \end{pmatrix} : a, b, c, d \in \{0, 3, 5, 7, 11, 13, 17, 19\} \right\}$. Then the number of invertible matrices in R is

Q.13 Let C_1 be the circle of radius 1 with center at the origin. Let C_2 be the circle of radius r with center at the point $A = (4,1)$, where $1 < r < 3$. Two distinct common tangents PQ and ST of C_1 and C_2 are drawn. The tangent PQ touches C_1 at P and C_2 at Q . The tangent ST touches C_1 at S and C_2 at T . Mid points of the line segments PQ and ST are joined to form a line which meets the x -axis at a point B . If $AB = \sqrt{5}$, then the value of r^2 is

SECTION 4 (Maximum Marks: 12)

- This section contains **TWO (02)** paragraphs.
- Based on each paragraph, there are **TWO (02)** questions.
- The answer to each question is a **NUMERICAL VALUE**.
- For each question, enter the correct numerical value of the answer using the mouse and the on-screen virtual numeric keypad in the place designated to enter the answer.
- If the numerical value has more than two decimal places, **truncate/round-off** the value to **TWO** decimal places.
- Answer to each question will be evaluated according to the following marking scheme:
Full Marks : +3 If ONLY the correct numerical value is entered in the designated place;
Zero Marks : 0 In all other cases.

PARAGRAPH “I”

Consider an obtuse angled triangle ABC in which the difference between the largest and the smallest angle is $\frac{\pi}{2}$ and whose sides are in arithmetic progression. Suppose that the vertices of this triangle lie on a circle of radius 1.

(There are two questions based on PARAGRAPH “I”, the question given below is one of them)

Q.14 Let a be the area of the triangle ABC . Then the value of $(64a)^2$ is

PARAGRAPH “I”

Consider an obtuse angled triangle ABC in which the difference between the largest and the smallest angle is $\frac{\pi}{2}$ and whose sides are in arithmetic progression. Suppose that the vertices of this triangle lie on a circle of radius 1.

(There are two questions based on PARAGRAPH “I”, the question given below is one of them)

Q.15 Then the inradius of the triangle ABC is

PARAGRAPH "II"

Consider the 6×6 square in the figure. Let A_1, A_2, \dots, A_{49} be the points of intersections (dots in the picture) in some order. We say that A_i and A_j are friends if they are adjacent along a row or along a column. Assume that each point A_i has an equal chance of being chosen.

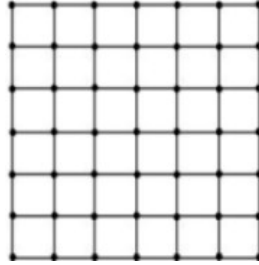

(There are two questions based on PARAGRAPH "II", the question given below is one of them)

- Q.16 Let p_i be the probability that a randomly chosen point has i many friends, $i = 0, 1, 2, 3, 4$. Let X be a random variable such that for $i = 0, 1, 2, 3, 4$, the probability $P(X = i) = p_i$. Then the value of $7E(X)$ is

PARAGRAPH "II"

Consider the 6×6 square in the figure. Let A_1, A_2, \dots, A_{49} be the points of intersections (dots in the picture) in some order. We say that A_i and A_j are friends if they are adjacent along a row or along a column. Assume that each point A_i has an equal chance of being chosen.

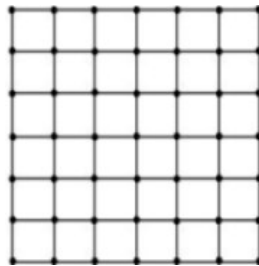

(There are two questions based on PARAGRAPH "II", the question given below is one of them)

- Q.17 Two distinct points are chosen randomly out of the points A_1, A_2, \dots, A_{49} . Let p be the probability that they are friends. Then the value of $7p$ is

END OF THE QUESTION PAPER

Physics

SECTION 1 (Maximum Marks: 12)

- This section contains **FOUR (04)** questions.
- Each question has **FOUR** options (A), (B), (C) and (D). **ONLY ONE** of these four options is the correct answer.
- For each question, choose the option corresponding to the correct answer.
- Answer to each question will be evaluated according to the following marking scheme:
Full Marks : +3 If **ONLY** the correct option is chosen;
Zero Marks : 0 If none of the options is chosen (i.e. the question is unanswered);
Negative Marks : -1 In all other cases.

Q.1 An electric dipole is formed by two charges $+q$ and $-q$ located in xy -plane at $(0,2)$ mm and $(0,-2)$ mm, respectively, as shown in the figure. The electric potential at point P $(100,100)$ mm due to the dipole is V_0 . The charges $+q$ and $-q$ are then moved to the points $(-1,2)$ mm and $(1,-2)$ mm, respectively. What is the value of electric potential at P due to the new dipole?

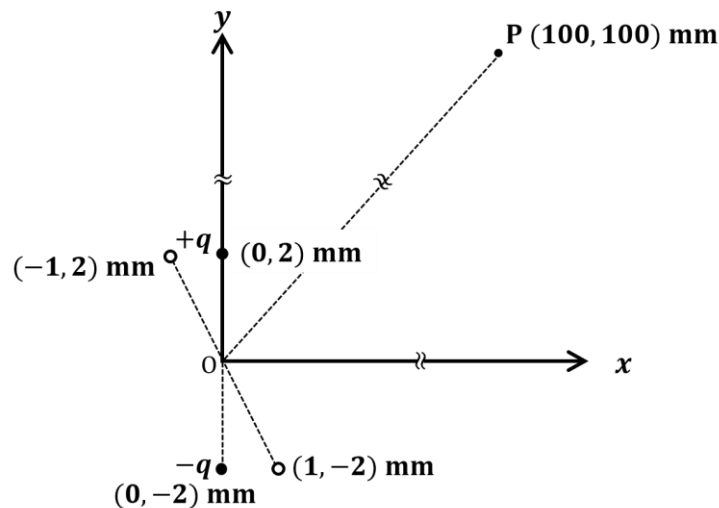

- (A) $V_0/4$ (B) $V_0/2$ (C) $V_0/\sqrt{2}$ (D) $3V_0/4$

Q.2 Young's modulus of elasticity Y is expressed in terms of three derived quantities, namely, the gravitational constant G , Planck's constant h and the speed of light c , as $Y = c^\alpha h^\beta G^\gamma$. Which of the following is the correct option?

- (A) $\alpha = 7, \beta = -1, \gamma = -2$ (B) $\alpha = -7, \beta = -1, \gamma = -2$
 (C) $\alpha = 7, \beta = -1, \gamma = 2$ (D) $\alpha = -7, \beta = 1, \gamma = -2$

Q.3 A particle of mass m is moving in the xy -plane such that its velocity at a point (x, y) is given as $\vec{v} = \alpha(y\hat{x} + 2x\hat{y})$, where α is a non-zero constant. What is the force \vec{F} acting on the particle?

- (A) $\vec{F} = 2m\alpha^2(x\hat{x} + y\hat{y})$ (B) $\vec{F} = m\alpha^2(y\hat{x} + 2x\hat{y})$
 (C) $\vec{F} = 2m\alpha^2(y\hat{x} + x\hat{y})$ (D) $\vec{F} = m\alpha^2(x\hat{x} + 2y\hat{y})$

Q.4 An ideal gas is in thermodynamic equilibrium. The number of degrees of freedom of a molecule of the gas is n . The internal energy of one mole of the gas is U_n and the speed of sound in the gas is v_n . At a fixed temperature and pressure, which of the following is the correct option?

(A) $v_3 < v_6$ and $U_3 > U_6$

(B) $v_5 > v_3$ and $U_3 > U_5$

(C) $v_5 > v_7$ and $U_5 < U_7$

(D) $v_6 < v_7$ and $U_6 < U_7$

SECTION 2 (Maximum Marks: 12)

- This section contains **THREE (03)** questions.
 - Each question has **FOUR** options (A), (B), (C) and (D). **ONE OR MORE THAN ONE** of these four option(s) is (are) correct answer(s).
 - For each question, choose the option(s) corresponding to (all) the correct answer(s).
 - Answer to each question will be evaluated according to the following marking scheme:
 - Full Marks* : +4 **ONLY** if (all) the correct option(s) is(are) chosen;
 - Partial Marks* : +3 If all the four options are correct but **ONLY** three options are chosen;
 - Partial Marks* : +2 If three or more options are correct but **ONLY** two options are chosen, both of which are correct;
 - Partial Marks* : +1 If two or more options are correct but **ONLY** one option is chosen and it is a correct option;
 - Zero Marks* : 0 If unanswered;
 - Negative Marks* : -2 In all other cases.
 - For example, in a question, if (A), (B) and (D) are the **ONLY** three options corresponding to correct answers, then
 - choosing **ONLY** (A), (B) and (D) will get +4 marks;
 - choosing **ONLY** (A) and (B) will get +2 marks;
 - choosing **ONLY** (A) and (D) will get +2marks;
 - choosing **ONLY** (B) and (D) will get +2 marks;
 - choosing **ONLY** (A) will get +1 mark;
 - choosing **ONLY** (B) will get +1 mark;
 - choosing **ONLY** (D) will get +1 mark;
 - choosing no option(s) (i.e. the question is unanswered) will get 0 marks and
 - choosing any other option(s) will get -2 marks.
-

- Q.5 A monochromatic light wave is incident normally on a glass slab of thickness d , as shown in the figure. The refractive index of the slab increases linearly from n_1 to n_2 over the height h . Which of the following statement(s) is(are) true about the light wave emerging out of the slab?

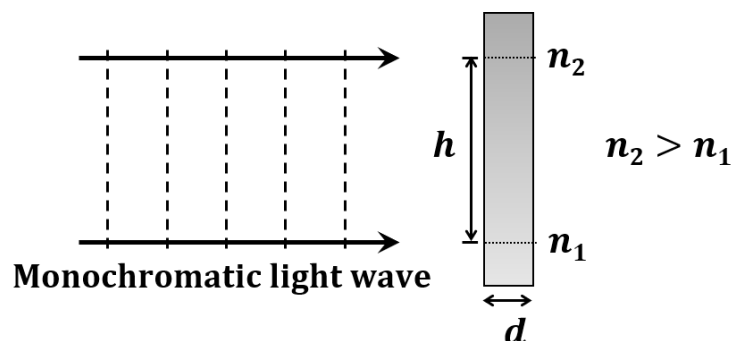

- (A) It will deflect up by an angle $\tan^{-1} \left[\frac{(n_2^2 - n_1^2)d}{2h} \right]$.
- (B) It will deflect up by an angle $\tan^{-1} \left[\frac{(n_2 - n_1)d}{h} \right]$.
- (C) It will not deflect.
- (D) The deflection angle depends only on $(n_2 - n_1)$ and not on the individual values of n_1 and n_2 .
- Q.6 An annular disk of mass M , inner radius a and outer radius b is placed on a horizontal surface with coefficient of friction μ , as shown in the figure. At some time, an impulse $\mathcal{J}_0 \hat{x}$ is applied at a height h above the center of the disk. If $h = h_m$ then the disk rolls without slipping along the x -axis. Which of the following statement(s) is(are) correct?

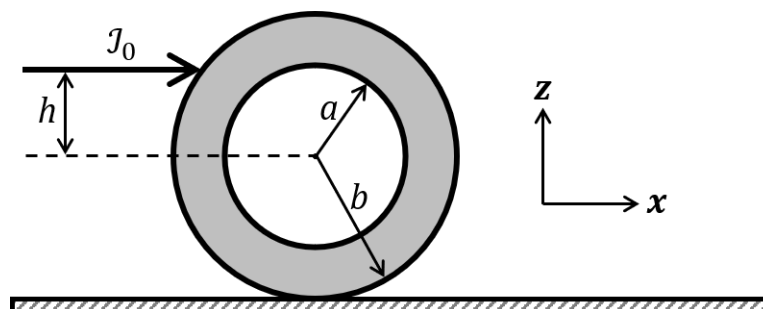

- (A) For $\mu \neq 0$ and $a \rightarrow 0$, $h_m = b/2$.
- (B) For $\mu \neq 0$ and $a \rightarrow b$, $h_m = b$.
- (C) For $h = h_m$, the initial angular velocity does **not** depend on the inner radius a .
- (D) For $\mu = 0$ and $h = 0$, the wheel always slides without rolling.

Q.7 The electric field associated with an electromagnetic wave propagating in a dielectric medium is given by $\vec{E} = 30(2\hat{x} + \hat{y})\sin\left[2\pi\left(5 \times 10^{14}t - \frac{10^7}{3}z\right)\right]$ V m⁻¹. Which of the following option(s) is(are) correct?

[Given: The speed of light in vacuum, $c = 3 \times 10^8$ m s⁻¹]

(A) $B_x = -2 \times 10^{-7} \sin\left[2\pi\left(5 \times 10^{14}t - \frac{10^7}{3}z\right)\right]$ Wb m⁻².

(B) $B_y = 2 \times 10^{-7} \sin\left[2\pi\left(5 \times 10^{14}t - \frac{10^7}{3}z\right)\right]$ Wb m⁻².

(C) The wave is polarized in the xy -plane with polarization angle 30° with respect to the x -axis.

(D) The refractive index of the medium is 2.

SECTION 3 (Maximum Marks: 24)

- This section contains **SIX (06)** questions.
- The answer to each question is a **NON-NEGATIVE INTEGER**.
- For each question, enter the correct integer corresponding to the answer using the mouse and the on-screen virtual numeric keypad in the place designated to enter the answer.
- Answer to each question will be evaluated according to the following marking scheme:
Full Marks : +4 If **ONLY** the correct integer is entered;
Zero Marks : 0 In all other cases.

Q.8 A thin circular coin of mass 5 gm and radius $\frac{4}{3}$ cm is initially in a horizontal xy -plane. The coin is tossed vertically up ($+z$ direction) by applying an impulse of $\sqrt{\frac{\pi}{2}} \times 10^{-2}$ N-s at a distance $\frac{2}{3}$ cm from its center. The coin spins about its diameter and moves along the $+z$ direction. By the time the coin reaches back to its initial position, it completes n rotations. The value of n is ____.

[Given: The acceleration due to gravity $g = 10 \text{ m s}^{-2}$]

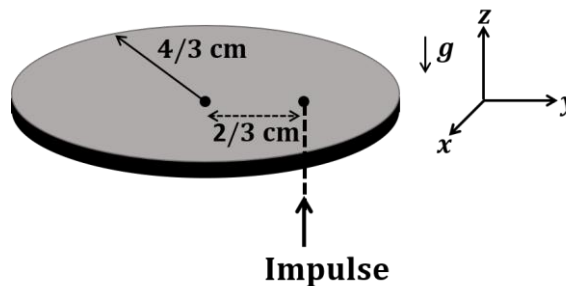

Q.9 A rectangular conducting loop of length 4 cm and width 2 cm is in the xy -plane, as shown in the figure. It is being moved away from a thin and long conducting wire along the direction $\frac{\sqrt{3}}{2} \hat{x} + \frac{1}{2} \hat{y}$ with a constant speed v . The wire is carrying a steady current $I = 10 \text{ A}$ in the positive x -direction. A current of $10 \mu\text{A}$ flows through the loop when it is at a distance $d = 4 \text{ cm}$ from the wire. If the resistance of the loop is 0.1Ω , then the value of v is _____ m s^{-1} .

[Given: The permeability of free space $\mu_0 = 4\pi \times 10^{-7} \text{ N A}^{-2}$]

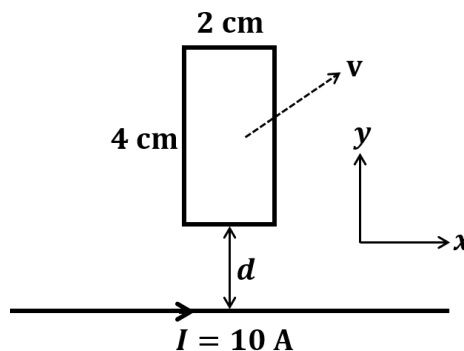

Q.10 A string of length 1 m and mass 2×10^{-5} kg is under tension T . When the string vibrates, two successive harmonics are found to occur at frequencies 750 Hz and 1000 Hz. The value of tension T is _____ Newton.

Q.11 An incompressible liquid is kept in a container having a weightless piston with a hole. A capillary tube of inner radius 0.1 mm is dipped vertically into the liquid through the airtight piston hole, as shown in the figure. The air in the container is isothermally compressed from its original volume V_0 to $\frac{100}{101}V_0$ with the movable piston. Considering air as an ideal gas, the height (h) of the liquid column in the capillary above the liquid level in cm is _____.

[Given: Surface tension of the liquid is 0.075 N m^{-1} , atmospheric pressure is 10^5 N m^{-2} , acceleration due to gravity (g) is 10 m s^{-2} , density of the liquid is 10^3 kg m^{-3} and contact angle of capillary surface with the liquid is zero]

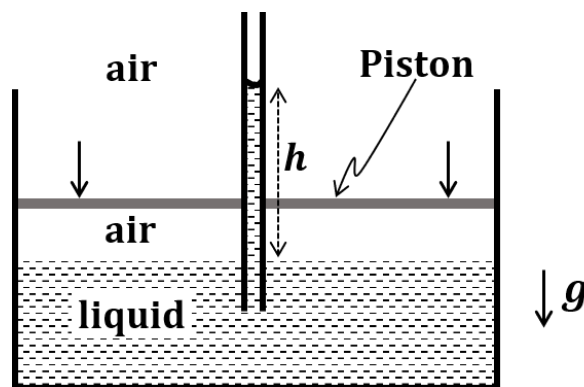

Q.12 In a radioactive decay process, the activity is defined as $A = -\frac{dN}{dt}$, where $N(t)$ is the number of radioactive nuclei at time t . Two radioactive sources, S_1 and S_2 have same activity at time $t = 0$. At a later time, the activities of S_1 and S_2 are A_1 and A_2 , respectively. When S_1 and S_2 have just completed their 3rd and 7th half-lives, respectively, the ratio A_1/A_2 is _____.

Q.13 One mole of an ideal gas undergoes two different cyclic processes I and II, as shown in the P - V diagrams below. In cycle I, processes a, b, c and d are isobaric, isothermal, isobaric and isochoric, respectively. In cycle II, processes a', b', c' and d' are isothermal, isochoric, isobaric and isochoric, respectively. The total work done during cycle I is W_I and that during cycle II is W_{II} . The ratio W_I/W_{II} is _____.

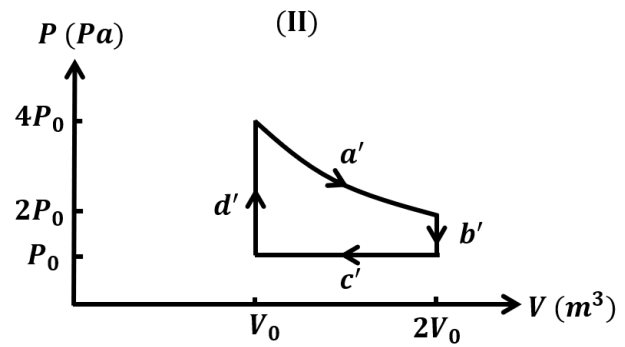
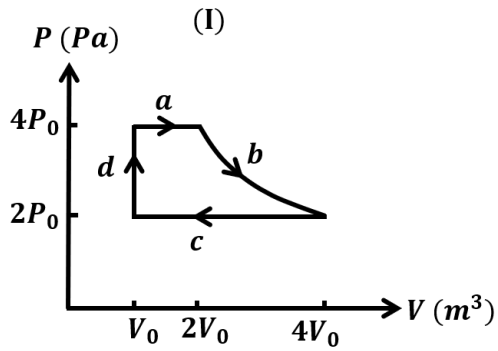

SECTION 4 (Maximum Marks: 12)

- This section contains **TWO (02)** paragraphs.
- Based on each paragraph, there are **TWO (02)** questions.
- The answer to each question is a **NUMERICAL VALUE**.
- For each question, enter the correct numerical value of the answer using the mouse and the on-screen virtual numeric keypad in the place designated to enter the answer.
- If the numerical value has more than two decimal places, **truncate/round-off** the value to **TWO** decimal places.
- Answer to each question will be evaluated according to the following marking scheme:
Full Marks : +3 If **ONLY** the correct numerical value is entered in the designated place;
Zero Marks : 0 In all other cases.

PARAGRAPH I

S_1 and S_2 are two identical sound sources of frequency 656 Hz. The source S_1 is located at O and S_2 moves anti-clockwise with a uniform speed $4\sqrt{2} \text{ m s}^{-1}$ on a circular path around O , as shown in the figure. There are three points P , Q and R on this path such that P and R are diametrically opposite while Q is equidistant from them. A sound detector is placed at point P . The source S_1 can move along direction OP .

[Given: The speed of sound in air is 324 m s^{-1}]

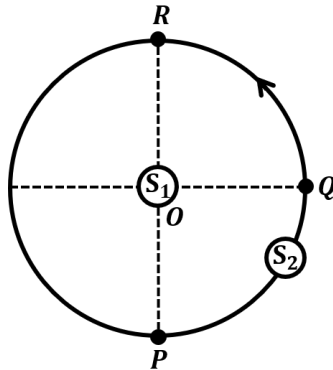

- Q.14 When only S_2 is emitting sound and it is at Q , the frequency of sound measured by the detector in Hz is _____.

PARAGRAPH I

S_1 and S_2 are two identical sound sources of frequency 656 Hz. The source S_1 is located at O and S_2 moves anti-clockwise with a uniform speed $4\sqrt{2} \text{ m s}^{-1}$ on a circular path around O , as shown in the figure. There are three points P , Q and R on this path such that P and R are diametrically opposite while Q is equidistant from them. A sound detector is placed at point P . The source S_1 can move along direction OP .

[Given: The speed of sound in air is 324 m s^{-1}]

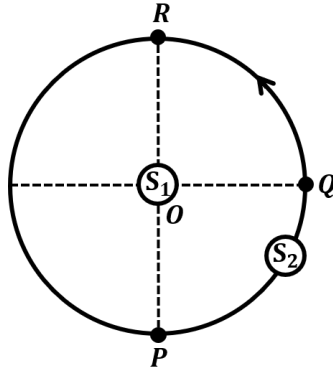

- Q.15 Consider both sources emitting sound. When S_2 is at R and S_1 approaches the detector with a speed 4 m s^{-1} , the beat frequency measured by the detector is _____ Hz.
-

PARAGRAPH II

A cylindrical furnace has height (H) and diameter (D) both 1 m. It is maintained at temperature 360 K. The air gets heated inside the furnace at constant pressure P_a and its temperature becomes $T = 360$ K. The hot air with density ρ rises up a vertical chimney of diameter $d = 0.1$ m and height $h = 9$ m above the furnace and exits the chimney (see the figure). As a result, atmospheric air of density $\rho_a = 1.2 \text{ kg m}^{-3}$, pressure P_a and temperature $T_a = 300$ K enters the furnace. Assume air as an ideal gas, neglect the variations in ρ and T inside the chimney and the furnace. Also ignore the viscous effects.

[Given: The acceleration due to gravity $g = 10 \text{ m s}^{-2}$ and $\pi = 3.14$]

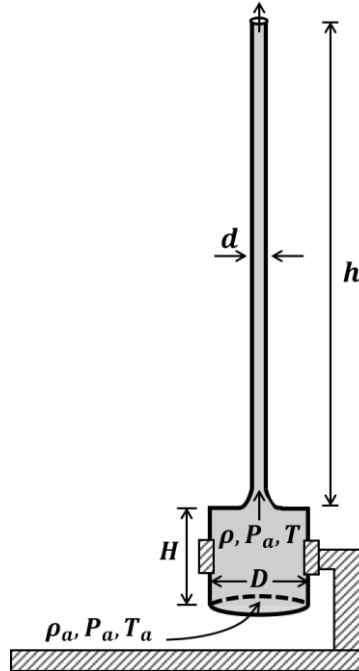

- Q.16 Considering the air flow to be streamline, the steady mass flow rate of air exiting the chimney is _____ gm s^{-1} .

PARAGRAPH II

A cylindrical furnace has height (H) and diameter (D) both 1 m. It is maintained at temperature 360 K. The air gets heated inside the furnace at constant pressure P_a and its temperature becomes $T = 360$ K. The hot air with density ρ rises up a vertical chimney of diameter $d = 0.1$ m and height $h = 9$ m above the furnace and exits the chimney (see the figure). As a result, atmospheric air of density $\rho_a = 1.2 \text{ kg m}^{-3}$, pressure P_a and temperature $T_a = 300$ K enters the furnace. Assume air as an ideal gas, neglect the variations in ρ and T inside the chimney and the furnace. Also ignore the viscous effects.

[Given: The acceleration due to gravity $g = 10 \text{ m s}^{-2}$ and $\pi = 3.14$]

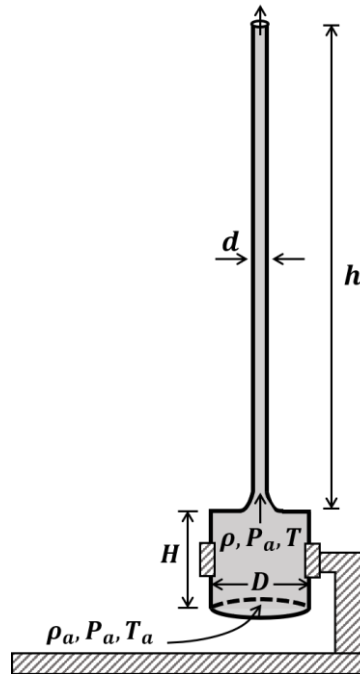

- Q.17 When the chimney is closed using a cap at the top, a pressure difference ΔP develops between the top and the bottom surfaces of the cap. If the changes in the temperature and density of the hot air, due to the stoppage of air flow, are negligible then the value of ΔP is _____ N m^{-2} .

END OF THE QUESTION PAPER

Chemistry

SECTION 1 (Maximum Marks: 12)

- This section contains **FOUR (04)** questions.
- Each question has **FOUR** options (A), (B), (C) and (D). **ONLY ONE** of these four options is the correct answer.
- For each question, choose the option corresponding to the correct answer.
- Answer to each question will be evaluated according to the following marking scheme:
Full Marks : +3 If **ONLY** the correct option is chosen;
Zero Marks : 0 If none of the options is chosen (i.e. the question is unanswered);
Negative Marks : -1 In all other cases.

Q.1 The correct molecular orbital diagram for F_2 molecule in the ground state is

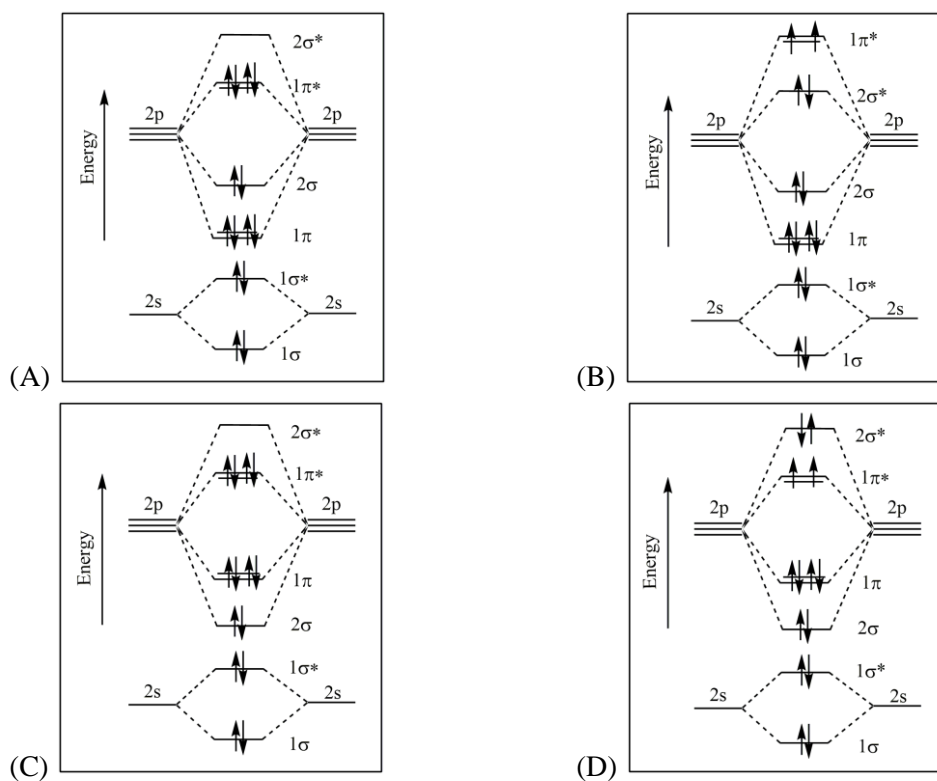

Q.2 Consider the following statements related to colloids.

- (I) Lyophobic colloids are **not** formed by simple mixing of dispersed phase and dispersion medium.
(II) For emulsions, both the dispersed phase and the dispersion medium are liquid.
(III) Micelles are produced by dissolving a surfactant in any solvent at any temperature.
(IV) Tyndall effect can be observed from a colloidal solution with dispersed phase having the same refractive index as that of the dispersion medium.

The option with the correct set of statements is

- (A) (I) and (II)
(B) (II) and (III)
(C) (III) and (IV)
(D) (II) and (IV)

Q.3 In the following reactions, **P**, **Q**, **R**, and **S** are the major products.

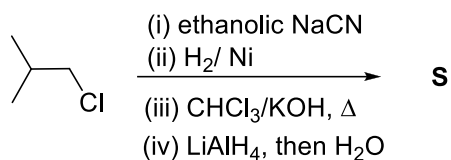
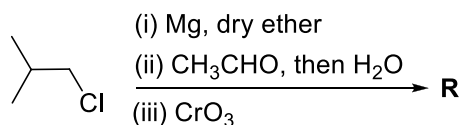
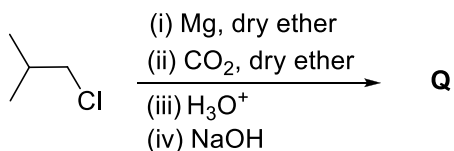
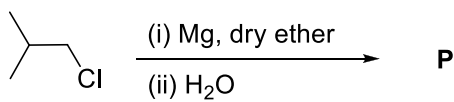

The correct statement about **P**, **Q**, **R**, and **S** is

- (A) **P** is a primary alcohol with four carbons.
(B) **Q** undergoes Kolbe's electrolysis to give an eight-carbon product.
(C) **R** has six carbons and it undergoes Cannizzaro reaction.
(D) **S** is a primary amine with six carbons.
-

Q.4 A disaccharide **X** cannot be oxidised by bromine water. The acid hydrolysis of **X** leads to a laevorotatory solution. The disaccharide **X** is

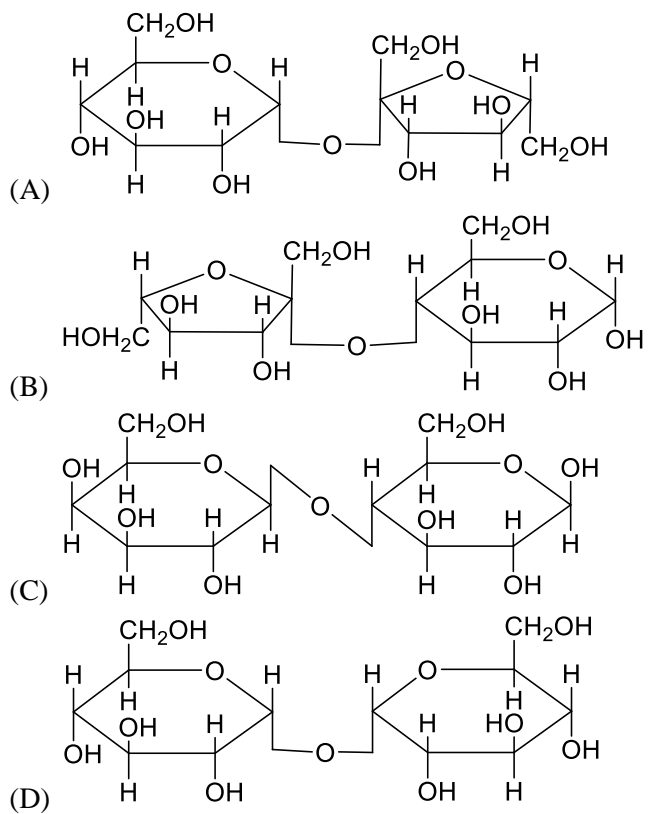

SECTION 2 (Maximum Marks: 12)

- This section contains **THREE (03)** questions.
- Each question has **FOUR** options (A), (B), (C) and (D). **ONE OR MORE THAN ONE** of these four option(s) is (are) correct answer(s).
- For each question, choose the option(s) corresponding to (all) the correct answer(s).
- Answer to each question will be evaluated according to the following marking scheme:
 - Full Marks* : +4 **ONLY** if (all) the correct option(s) is(are) chosen;
 - Partial Marks* : +3 If all the four options are correct but **ONLY** three options are chosen;
 - Partial Marks* : +2 If three or more options are correct but **ONLY** two options are chosen, both of which are correct;
 - Partial Marks* : +1 If two or more options are correct but **ONLY** one option is chosen and it is a correct option;
 - Zero Marks* : 0 If unanswered;
 - Negative Marks* : -2 In all other cases.
- For example, in a question, if (A), (B) and (D) are the **ONLY** three options corresponding to correct answers, then
 - choosing **ONLY** (A), (B) and (D) will get +4 marks;
 - choosing **ONLY** (A) and (B) will get +2 marks;
 - choosing **ONLY** (A) and (D) will get +2marks;
 - choosing **ONLY** (B) and (D) will get +2 marks;
 - choosing **ONLY** (A) will get +1 mark;
 - choosing **ONLY** (B) will get +1 mark;
 - choosing **ONLY** (D) will get +1 mark;
 - choosing no option(s) (i.e. the question is unanswered) will get 0 marks and
 - choosing any other option(s) will get -2 marks.

Q.5 The complex(es), which can exhibit the type of isomerism shown by $[\text{Pt}(\text{NH}_3)_2\text{Br}_2]$, is(are)
[en = $\text{H}_2\text{NCH}_2\text{CH}_2\text{NH}_2$]

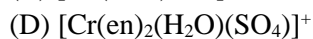
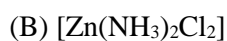
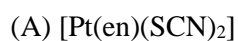

Q.6 Atoms of metals x, y, and z form face-centred cubic (fcc) unit cell of edge length L_x , body-centred cubic (bcc) unit cell of edge length L_y , and simple cubic unit cell of edge length L_z , respectively.

If $r_z = \frac{\sqrt{3}}{2} r_y$; $r_y = \frac{8}{\sqrt{3}} r_x$; $M_z = \frac{3}{2} M_y$ and $M_z = 3M_x$, then the correct statement(s) is(are)

[Given: M_x , M_y , and M_z are molar masses of metals x, y, and z, respectively.

r_x , r_y , and r_z are atomic radii of metals x, y, and z, respectively.]

(A) Packing efficiency of unit cell of x > Packing efficiency of unit cell of y > Packing efficiency of unit cell of z

(B) $L_y > L_z$

(C) $L_x > L_y$

(D) Density of x > Density of y

Q.7 In the following reactions, **P**, **Q**, **R**, and **S** are the major products.

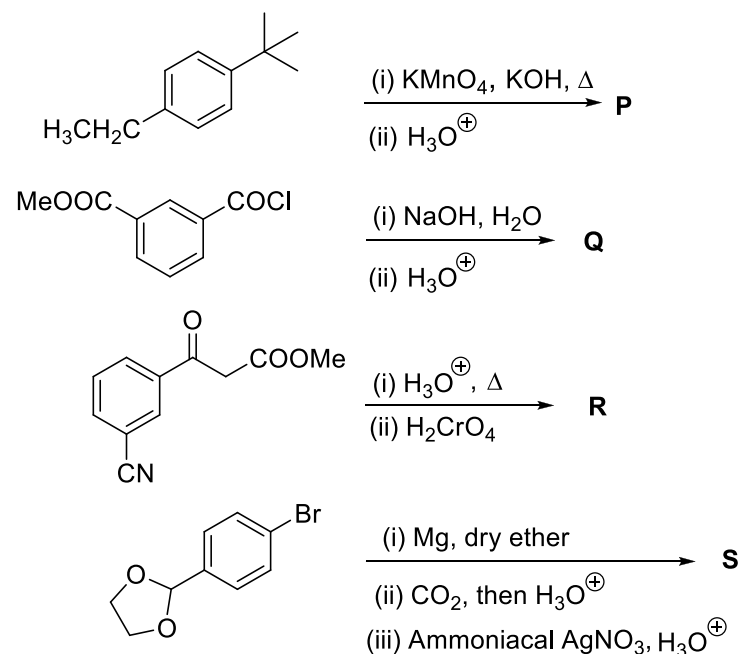

The correct statement(s) about **P**, **Q**, **R**, and **S** is(are)

(A) **P** and **Q** are monomers of polymers dacron and glyptal, respectively.

(B) **P**, **Q**, and **R** are dicarboxylic acids.

(C) Compounds **Q** and **R** are the same.

(D) **R** does **not** undergo aldol condensation and **S** does **not** undergo Cannizzaro reaction.

SECTION 3 (Maximum Marks: 24)

- This section contains **SIX (06)** questions.
- The answer to each question is a **NON-NEGATIVE INTEGER**.
- For each question, enter the correct integer corresponding to the answer using the mouse and the on-screen virtual numeric keypad in the place designated to enter the answer.
- Answer to each question will be evaluated according to the following marking scheme:
Full Marks : +4 If **ONLY** the correct integer is entered;
Zero Marks : 0 In all other cases.

- Q.8 H₂S (5 moles) reacts completely with acidified aqueous potassium permanganate solution. In this reaction, the number of moles of water produced is **x**, and the number of moles of electrons involved is **y**. The value of (**x + y**) is ____.
- Q.9 Among [I₃]⁺, [SiO₄]⁴⁻, SO₂Cl₂, XeF₂, SF₄, ClF₃, Ni(CO)₄, XeO₂F₂, [PtCl₄]²⁻, XeF₄, and SOCl₂, the total number of species having *sp*³ hybridised central atom is _____.
- Q.10 Consider the following molecules: Br₃O₈, F₂O, H₂S₄O₆, H₂S₅O₆, and C₃O₂.
Count the number of atoms existing in their zero oxidation state in each molecule.
Their sum is ____.
- Q.11 For He⁺, a transition takes place from the orbit of radius 105.8 pm to the orbit of radius 26.45 pm.
The wavelength (in nm) of the emitted photon during the transition is ____.

[Use:

Bohr radius, $a = 52.9 \text{ pm}$

Rydberg constant, $R_H = 2.2 \times 10^{-18} \text{ J}$

Planck's constant, $h = 6.6 \times 10^{-34} \text{ J s}$

Speed of light, $c = 3 \times 10^8 \text{ m s}^{-1}$]

Q.12 50 mL of 0.2 molal urea solution (density = 1.012 g mL^{-1} at 300 K) is mixed with 250 mL of a solution containing 0.06 g of urea. Both the solutions were prepared in the same solvent. The osmotic pressure (in Torr) of the resulting solution at 300 K is ____.

[Use: Molar mass of urea = 60 g mol^{-1} ; gas constant, $R = 62 \text{ L Torr K}^{-1} \text{ mol}^{-1}$;

Assume, $\Delta_{\text{mix}}H = 0$, $\Delta_{\text{mix}}V = 0$]

Q.13 The reaction of 4-methyloct-1-ene (**P**, 2.52 g) with HBr in the presence of $(\text{C}_6\text{H}_5\text{CO})_2\text{O}_2$ gives two isomeric bromides in a 9 : 1 ratio, with a combined yield of 50%. Of these, the entire amount of the primary alkyl bromide was reacted with an appropriate amount of diethylamine followed by treatment with aq. K_2CO_3 to give a non-ionic product **S** in 100% yield.

The mass (in mg) of **S** obtained is ____.

[Use molar mass (in g mol^{-1}): H = 1, C = 12, N = 14, Br = 80]

SECTION 4 (Maximum Marks: 12)

- This section contains **TWO (02)** paragraphs.
- Based on each paragraph, there are **TWO (02)** questions.
- The answer to each question is a **NUMERICAL VALUE**.
- For each question, enter the correct numerical value of the answer using the mouse and the on-screen virtual numeric keypad in the place designated to enter the answer.
- If the numerical value has more than two decimal places, **truncate/round-off** the value to **TWO** decimal places.
- Answer to each question will be evaluated according to the following marking scheme:
Full Marks : +3 If ONLY the correct numerical value is entered in the designated place;
Zero Marks : 0 In all other cases.

“PARAGRAPH I”

The entropy versus temperature plot for phases α and β at 1 bar pressure is given.
 S_T and S_0 are entropies of the phases at temperatures T and 0 K, respectively.

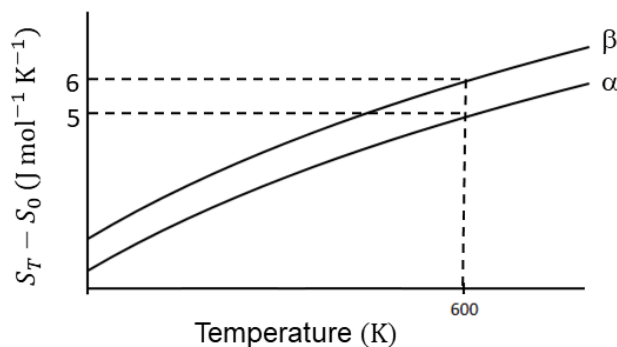

The transition temperature for α to β phase change is 600 K and $C_{p,\beta} - C_{p,\alpha} = 1 \text{ J mol}^{-1} \text{ K}^{-1}$. Assume $(C_{p,\beta} - C_{p,\alpha})$ is independent of temperature in the range of 200 to 700 K. $C_{p,\alpha}$ and $C_{p,\beta}$ are heat capacities of α and β phases, respectively.

Q.14 The value of entropy change, $S_\beta - S_\alpha$ (in $\text{J mol}^{-1} \text{ K}^{-1}$), at 300 K is ____.

[Use: $\ln 2 = 0.69$

Given: $S_\beta - S_\alpha = 0$ at 0 K]

“PARAGRAPH I”

The entropy versus temperature plot for phases α and β at 1 bar pressure is given. S_T and S_0 are entropies of the phases at temperatures T and 0 K, respectively.

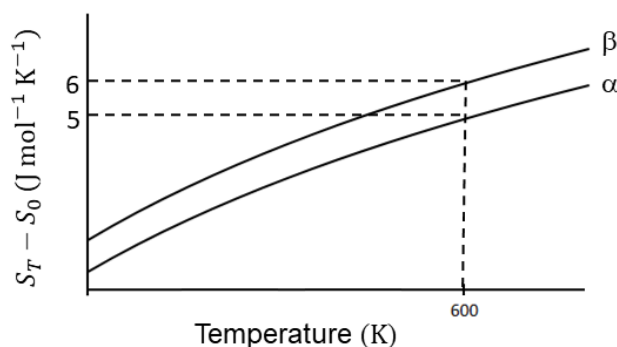

The transition temperature for α to β phase change is 600 K and $C_{p,\beta} - C_{p,\alpha} = 1 \text{ J mol}^{-1} \text{ K}^{-1}$. Assume $(C_{p,\beta} - C_{p,\alpha})$ is independent of temperature in the range of 200 to 700 K. $C_{p,\alpha}$ and $C_{p,\beta}$ are heat capacities of α and β phases, respectively.

Q.15 The value of enthalpy change, $H_\beta - H_\alpha$ (in J mol^{-1}), at 300 K is ____.

“PARAGRAPH II”

A trinitro compound, 1,3,5-tris-(4-nitrophenyl)benzene, on complete reaction with an excess of Sn/HCl gives a major product, which on treatment with an excess of NaNO_2/HCl at 0°C provides **P** as the product. **P**, upon treatment with excess of H_2O at room temperature, gives the product **Q**. Bromination of **Q** in aqueous medium furnishes the product **R**. The compound **P** upon treatment with an excess of phenol under basic conditions gives the product **S**.

The molar mass difference between compounds **Q** and **R** is 474 g mol^{-1} and between compounds **P** and **S** is 172.5 g mol^{-1} .

Q.16 The number of heteroatoms present in one molecule of **R** is _____ .

[Use: Molar mass (in g mol^{-1}): H = 1, C = 12, N = 14, O = 16, Br = 80, Cl = 35.5
Atoms other than C and H are considered as heteroatoms]

“PARAGRAPH II”

A trinitro compound, 1,3,5-tris-(4-nitrophenyl)benzene, on complete reaction with an excess of Sn/HCl gives a major product, which on treatment with an excess of NaNO₂/HCl at 0 °C provides **P** as the product. **P**, upon treatment with excess of H₂O at room temperature, gives the product **Q**. Bromination of **Q** in aqueous medium furnishes the product **R**. The compound **P** upon treatment with an excess of phenol under basic conditions gives the product **S**.

The molar mass difference between compounds **Q** and **R** is 474 g mol⁻¹ and between compounds **P** and **S** is 172.5 g mol⁻¹.

Q.17 The total number of carbon atoms and heteroatoms present in one molecule of **S** is _____ .

[Use: Molar mass (in g mol⁻¹): H = 1, C = 12, N = 14, O = 16, Br = 80, Cl = 35.5

Atoms other than C and H are considered as heteroatoms]

END OF THE QUESTION PAPER

Final Answer Keys

Mathematics

SECTION 1 (Maximum Marks: 12)

- This section contains **FOUR (04)** questions.
- Each question has **FOUR** options (A), (B), (C) and (D). **ONLY ONE** of these four options is the correct answer.
- For each question, choose the option corresponding to the correct answer.
- Answer to each question will be evaluated according to the following marking scheme:
Full Marks : +3 If **ONLY** the correct option is chosen;
Zero Marks : 0 If none of the options is chosen (i.e. the question is unanswered);
Negative Marks : -1 In all other cases.

Q.1 Let $f : [1, \infty) \rightarrow \mathbb{R}$ be a differentiable function such that $f(1) = \frac{1}{3}$ and

$3 \int_1^x f(t) dt = x f(x) - \frac{x^3}{3}$, $x \in [1, \infty)$. Let e denote the base of the natural logarithm. Then the value of $f(e)$ is

- (A) $\frac{e^2 + 4}{3}$ (B) $\frac{\log_e 4 + e}{3}$ (C) $\frac{4e^2}{3}$ (D) $\frac{e^2 - 4}{3}$

Answer: C

Q.2 Consider an experiment of tossing a coin repeatedly until the outcomes of two consecutive tosses are same. If the probability of a random toss resulting in head is $\frac{1}{3}$, then the probability that the experiment stops with head is

- (A) $\frac{1}{3}$ (B) $\frac{5}{21}$ (C) $\frac{4}{21}$ (D) $\frac{2}{7}$

Answer: B

Q.3 For any $y \in \mathbb{R}$, let $\cot^{-1}(y) \in (0, \pi)$ and $\tan^{-1}(y) \in \left(-\frac{\pi}{2}, \frac{\pi}{2}\right)$. Then the sum of all the solutions of the equation $\tan^{-1}\left(\frac{6y}{9-y^2}\right) + \cot^{-1}\left(\frac{9-y^2}{6y}\right) = \frac{2\pi}{3}$ for $0 < |y| < 3$, is equal to

- (A) $2\sqrt{3} - 3$ (B) $3 - 2\sqrt{3}$ (C) $4\sqrt{3} - 6$ (D) $6 - 4\sqrt{3}$

Answer: C

Q.4 Let the position vectors of the points P, Q, R and S be $\vec{a} = \hat{i} + 2\hat{j} - 5\hat{k}$, $\vec{b} = 3\hat{i} + 6\hat{j} + 3\hat{k}$,
 $\vec{c} = \frac{17}{5}\hat{i} + \frac{16}{5}\hat{j} + 7\hat{k}$ and $\vec{d} = 2\hat{i} + \hat{j} + \hat{k}$, respectively. Then which of the following statements is true?

- (A) The points P, Q, R and S are **NOT** coplanar
- (B) $\frac{\vec{b} + 2\vec{d}}{3}$ is the position vector of a point which divides PR internally in the ratio $5 : 4$
- (C) $\frac{\vec{b} + 2\vec{d}}{3}$ is the position vector of a point which divides PR externally in the ratio $5 : 4$
- (D) The square of the magnitude of the vector $\vec{b} \times \vec{d}$ is 95

Answer: B

SECTION 2 (Maximum Marks: 12)

- This section contains **THREE (03)** questions.
- Each question has **FOUR** options (A), (B), (C) and (D). **ONE OR MORE THAN ONE** of these four option(s) is (are) correct answer(s).
- For each question, choose the option(s) corresponding to (all) the correct answer(s).
- Answer to each question will be evaluated according to the following marking scheme:
 - Full Marks* : +4 **ONLY** if (all) the correct option(s) is(are) chosen;
 - Partial Marks* : +3 If all the four options are correct but **ONLY** three options are chosen;
 - Partial Marks* : +2 If three or more options are correct but **ONLY** two options are chosen, both of which are correct;
 - Partial Marks* : +1 If two or more options are correct but **ONLY** one option is chosen and it is a correct option;
 - Zero Marks* : 0 If unanswered;
 - Negative Marks* : -2 In all other cases.
- For example, in a question, if (A), (B) and (D) are the **ONLY** three options corresponding to correct answers, then
 - choosing **ONLY** (A), (B) and (D) will get +4 marks;
 - choosing **ONLY** (A) and (B) will get +2 marks;
 - choosing **ONLY** (A) and (D) will get +2 marks;
 - choosing **ONLY** (B) and (D) will get +2 marks;
 - choosing **ONLY** (A) will get +1 mark;
 - choosing **ONLY** (B) will get +1 mark;
 - choosing **ONLY** (D) will get +1 mark;
 - choosing no option(s) (i.e. the question is unanswered) will get 0 marks and
 - choosing any other option(s) will get -2 marks.

Q.5 Let $M = (a_{ij})$, $i, j \in \{1, 2, 3\}$, be the 3×3 matrix such that $a_{ij} = 1$ if $j+1$ is divisible by i , otherwise $a_{ij} = 0$. Then which of the following statements is(are) true?

(A) M is invertible

(B) There exists a nonzero column matrix $\begin{pmatrix} a_1 \\ a_2 \\ a_3 \end{pmatrix}$ such that $M \begin{pmatrix} a_1 \\ a_2 \\ a_3 \end{pmatrix} = \begin{pmatrix} -a_1 \\ -a_2 \\ -a_3 \end{pmatrix}$

(C) The set $\{X \in \mathbb{R}^3 : MX = \mathbf{0}\} \neq \{\mathbf{0}\}$, where $\mathbf{0} = \begin{pmatrix} 0 \\ 0 \\ 0 \end{pmatrix}$

(D) The matrix $(M - 2I)$ is invertible, where I is the 3×3 identity matrix

Answer: B, C

Q.6

Let $f : (0,1) \rightarrow \mathbb{R}$ be the function defined as $f(x) = [4x] \left(x - \frac{1}{4}\right)^2 \left(x - \frac{1}{2}\right)$, where $[x]$ denotes the greatest integer less than or equal to x . Then which of the following statements is(are) true?

- (A) The function f is discontinuous exactly at one point in $(0,1)$
- (B) There is exactly one point in $(0,1)$ at which the function f is continuous but **NOT** differentiable
- (C) The function f is **NOT** differentiable at more than three points in $(0,1)$
- (D) The minimum value of the function f is $-\frac{1}{512}$

Answer: A, B

Q.7

Let S be the set of all twice differentiable functions f from \mathbb{R} to \mathbb{R} such that $\frac{d^2 f}{dx^2}(x) > 0$ for all $x \in (-1,1)$. For $f \in S$, let X_f be the number of points $x \in (-1,1)$ for which $f(x) = x$. Then which of the following statements is(are) true?

- (A) There exists a function $f \in S$ such that $X_f = 0$
- (B) For every function $f \in S$, we have $X_f \leq 2$
- (C) There exists a function $f \in S$ such that $X_f = 2$
- (D) There does **NOT** exist any function f in S such that $X_f = 1$

Answer: A, B, C

SECTION 3 (Maximum Marks: 24)

- This section contains **SIX (06)** questions.
- The answer to each question is a **NON-NEGATIVE INTEGER**.
- For each question, enter the correct integer corresponding to the answer using the mouse and the on-screen virtual numeric keypad in the place designated to enter the answer.
- Answer to each question will be evaluated according to the following marking scheme:
Full Marks : +4 If **ONLY** the correct integer is entered;
Zero Marks : 0 In all other cases.

Q.8 For $x \in \mathbb{R}$, let $\tan^{-1}(x) \in \left(-\frac{\pi}{2}, \frac{\pi}{2}\right)$. Then the minimum value of the function

$$f: \mathbb{R} \rightarrow \mathbb{R} \text{ defined by } f(x) = \int_0^{x \tan^{-1} x} \frac{e^{(t-\cos t)}}{1+t^{2023}} dt \text{ is } \underline{0}.$$

Q.9 For $x \in \mathbb{R}$, let $y(x)$ be a solution of the differential equation

$$(x^2 - 5) \frac{dy}{dx} - 2xy = -2x(x^2 - 5)^2 \text{ such that } y(2) = 7.$$

Then the maximum value of the function $y(x)$ is 16.

Q.10 Let X be the set of all five digit numbers formed using 1,2,2,2,4,4,0. For example, 22240 is in X while 02244 and 44422 are not in X . Suppose that each element of X has an equal chance of being chosen. Let p be the conditional probability that an element chosen at random is a multiple of 20 given that it is a multiple of 5. Then the value of $38p$ is equal to 31.

Q.11 Let $A_1, A_2, A_3, \dots, A_8$ be the vertices of a regular octagon that lie on a circle of radius 2. Let P be a point on the circle and let PA_i denote the distance between the points P and A_i for $i = 1, 2, \dots, 8$. If P varies over the circle, then the maximum value of the product $PA_1 \cdot PA_2 \cdot \dots \cdot PA_8$, is 512.

Q.12 Let $R = \left\{ \begin{pmatrix} a & 3 & b \\ c & 2 & d \\ 0 & 5 & 0 \end{pmatrix} : a, b, c, d \in \{0, 3, 5, 7, 11, 13, 17, 19\} \right\}$. Then the number of invertible matrices in R is 3780.

Q.13 Let C_1 be the circle of radius 1 with center at the origin. Let C_2 be the circle of radius r with center at the point $A = (4,1)$, where $1 < r < 3$. Two distinct common tangents PQ and ST of C_1 and C_2 are drawn. The tangent PQ touches C_1 at P and C_2 at Q . The tangent ST touches C_1 at S and C_2 at T . Mid points of the line segments PQ and ST are joined to form a line which meets the x -axis at a point B . If $AB = \sqrt{5}$, then the value of r^2 is 2.

SECTION 4 (Maximum Marks: 12)

- This section contains **TWO (02)** paragraphs.
- Based on each paragraph, there are **TWO (02)** questions.
- The answer to each question is a **NUMERICAL VALUE**.
- For each question, enter the correct numerical value of the answer using the mouse and the on-screen virtual numeric keypad in the place designated to enter the answer.
- If the numerical value has more than two decimal places, **truncate/round-off** the value to **TWO** decimal places.
- Answer to each question will be evaluated according to the following marking scheme:
Full Marks : +3 If ONLY the correct numerical value is entered in the designated place;
Zero Marks : 0 In all other cases.

PARAGRAPH “I”

Consider an obtuse angled triangle ABC in which the difference between the largest and the smallest angle is $\frac{\pi}{2}$ and whose sides are in arithmetic progression. Suppose that the vertices of this triangle lie on a circle of radius 1.

(There are two questions based on PARAGRAPH “I”, the question given below is one of them)

Q.14 Let a be the area of the triangle ABC . Then the value of $(64a)^2$ is 1008.00.
Range (1007.99 to 1008.01)

PARAGRAPH “I”

Consider an obtuse angled triangle ABC in which the difference between the largest and the smallest angle is $\frac{\pi}{2}$ and whose sides are in arithmetic progression. Suppose that the vertices of this triangle lie on a circle of radius 1.

(There are two questions based on PARAGRAPH “I”, the question given below is one of them)

Q.15 Then the inradius of the triangle ABC is 0.25. Range(0.24 to 0.26)

PARAGRAPH "II"

Consider the 6×6 square in the figure. Let A_1, A_2, \dots, A_{49} be the points of intersections (dots in the picture) in some order. We say that A_i and A_j are friends if they are adjacent along a row or along a column. Assume that each point A_i has an equal chance of being chosen.

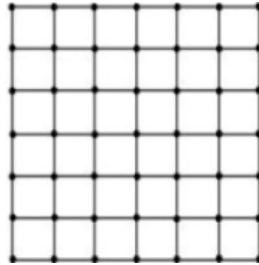

(There are two questions based on PARAGRAPH "II", the question given below is one of them)

- Q.16 Let p_i be the probability that a randomly chosen point has i many friends, $i = 0, 1, 2, 3, 4$. Let X be a random variable such that for $i = 0, 1, 2, 3, 4$, the probability $P(X = i) = p_i$. Then the value of $7E(X)$ is 24.00. Range (23.99 to 24.01)

PARAGRAPH "II"

Consider the 6×6 square in the figure. Let A_1, A_2, \dots, A_{49} be the points of intersections (dots in the picture) in some order. We say that A_i and A_j are friends if they are adjacent along a row or along a column. Assume that each point A_i has an equal chance of being chosen.

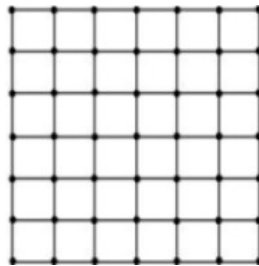

(There are two questions based on PARAGRAPH "II", the question given below is one of them)

- Q.17 Two distinct points are chosen randomly out of the points A_1, A_2, \dots, A_{49} . Let p be the probability that they are friends. Then the value of $7p$ is 0.50. Range (0.49 to 0.51)

END OF THE QUESTION PAPER

SECTION 1 (Maximum Marks: 12)

- This section contains **FOUR (04)** questions.
- Each question has **FOUR** options (A), (B), (C) and (D). **ONLY ONE** of these four options is the correct answer.
- For each question, choose the option corresponding to the correct answer.
- Answer to each question will be evaluated according to the following marking scheme:
Full Marks : +3 If **ONLY** the correct option is chosen;
Zero Marks : 0 If none of the options is chosen (i.e. the question is unanswered);
Negative Marks : -1 In all other cases.

Q.1 An electric dipole is formed by two charges $+q$ and $-q$ located in xy -plane at $(0,2)$ mm and $(0,-2)$ mm, respectively, as shown in the figure. The electric potential at point P $(100,100)$ mm due to the dipole is V_0 . The charges $+q$ and $-q$ are then moved to the points $(-1,2)$ mm and $(1,-2)$ mm, respectively. What is the value of electric potential at P due to the new dipole?

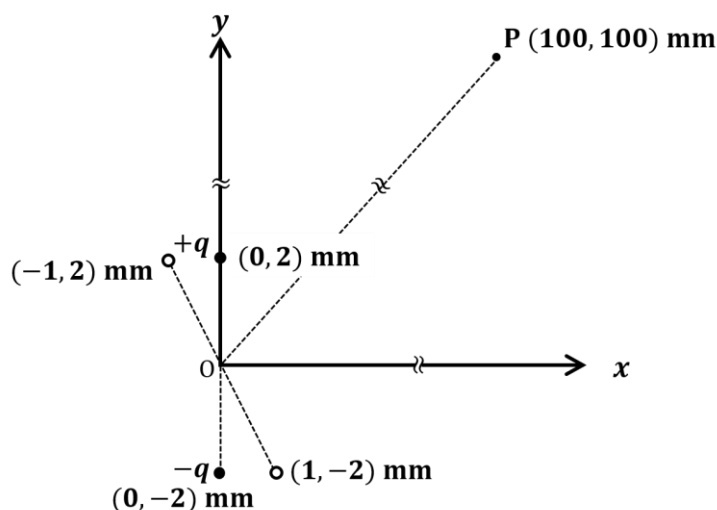

- (A) $V_0/4$ (B) $V_0/2$ (C) $V_0/\sqrt{2}$ (D) $3V_0/4$

Answer: B

Q.2 Young's modulus of elasticity Y is expressed in terms of three derived quantities, namely, the gravitational constant G , Planck's constant h and the speed of light c , as $Y = c^\alpha h^\beta G^\gamma$. Which of the following is the correct option?

- (A) $\alpha = 7, \beta = -1, \gamma = -2$ (B) $\alpha = -7, \beta = -1, \gamma = -2$
 (C) $\alpha = 7, \beta = -1, \gamma = 2$ (D) $\alpha = -7, \beta = 1, \gamma = -2$

Answer: A

Q.3 A particle of mass m is moving in the xy -plane such that its velocity at a point (x, y) is given as $\vec{v} = \alpha(y\hat{x} + 2x\hat{y})$, where α is a non-zero constant. What is the force \vec{F} acting on the particle?

- (A) $\vec{F} = 2m\alpha^2(x\hat{x} + y\hat{y})$ (B) $\vec{F} = m\alpha^2(y\hat{x} + 2x\hat{y})$
 (C) $\vec{F} = 2m\alpha^2(y\hat{x} + x\hat{y})$ (D) $\vec{F} = m\alpha^2(x\hat{x} + 2y\hat{y})$

Answer: A

Q.4 An ideal gas is in thermodynamic equilibrium. The number of degrees of freedom of a molecule of the gas is n . The internal energy of one mole of the gas is U_n and the speed of sound in the gas is v_n . At a fixed temperature and pressure, which of the following is the correct option?

(A) $v_3 < v_6$ and $U_3 > U_6$

(B) $v_5 > v_3$ and $U_3 > U_5$

(C) $v_5 > v_7$ and $U_5 < U_7$

(D) $v_6 < v_7$ and $U_6 < U_7$

Answer: C

SECTION 2 (Maximum Marks: 12)

- This section contains **THREE (03)** questions.
 - Each question has **FOUR** options (A), (B), (C) and (D). **ONE OR MORE THAN ONE** of these four option(s) is (are) correct answer(s).
 - For each question, choose the option(s) corresponding to (all) the correct answer(s).
 - Answer to each question will be evaluated according to the following marking scheme:
 - Full Marks* : +4 **ONLY** if (all) the correct option(s) is(are) chosen;
 - Partial Marks* : +3 If all the four options are correct but **ONLY** three options are chosen;
 - Partial Marks* : +2 If three or more options are correct but **ONLY** two options are chosen, both of which are correct;
 - Partial Marks* : +1 If two or more options are correct but **ONLY** one option is chosen and it is a correct option;
 - Zero Marks* : 0 If unanswered;
 - Negative Marks* : -2 In all other cases.
 - For example, in a question, if (A), (B) and (D) are the **ONLY** three options corresponding to correct answers, then
 - choosing **ONLY** (A), (B) and (D) will get +4 marks;
 - choosing **ONLY** (A) and (B) will get +2 marks;
 - choosing **ONLY** (A) and (D) will get +2marks;
 - choosing **ONLY** (B) and (D) will get +2 marks;
 - choosing **ONLY** (A) will get +1 mark;
 - choosing **ONLY** (B) will get +1 mark;
 - choosing **ONLY** (D) will get +1 mark;
 - choosing no option(s) (i.e. the question is unanswered) will get 0 marks and
 - choosing any other option(s) will get -2 marks.
-

- Q.5 A monochromatic light wave is incident normally on a glass slab of thickness d , as shown in the figure. The refractive index of the slab increases linearly from n_1 to n_2 over the height h . Which of the following statement(s) is(are) true about the light wave emerging out of the slab?

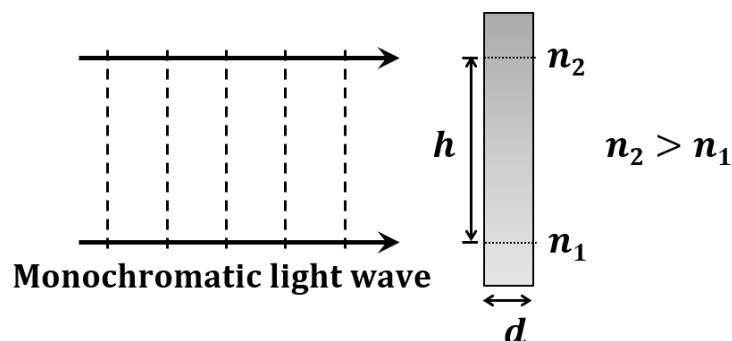

- (A) It will deflect up by an angle $\tan^{-1} \left[\frac{(n_2^2 - n_1^2)d}{2h} \right]$.
- (B) It will deflect up by an angle $\tan^{-1} \left[\frac{(n_2 - n_1)d}{h} \right]$.
- (C) It will not deflect.
- (D) The deflection angle depends only on $(n_2 - n_1)$ and not on the individual values of n_1 and n_2 .

Answer: B, D

- Q.6 An annular disk of mass M , inner radius a and outer radius b is placed on a horizontal surface with coefficient of friction μ , as shown in the figure. At some time, an impulse $J_0 \hat{x}$ is applied at a height h above the center of the disk. If $h = h_m$ then the disk rolls without slipping along the x -axis. Which of the following statement(s) is(are) correct?

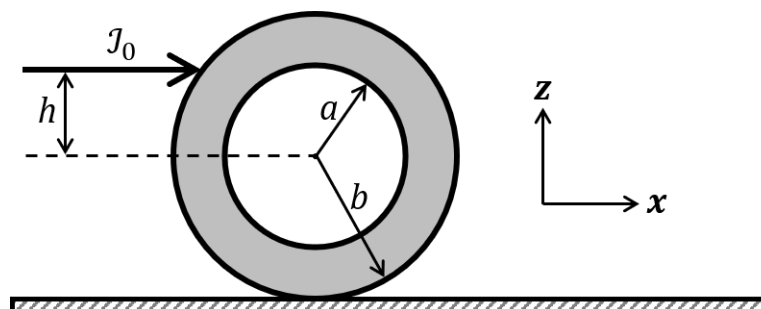

- (A) For $\mu \neq 0$ and $a \rightarrow 0$, $h_m = b/2$.
- (B) For $\mu \neq 0$ and $a \rightarrow b$, $h_m = b$.
- (C) For $h = h_m$, the initial angular velocity does **not** depend on the inner radius a .
- (D) For $\mu = 0$ and $h = 0$, the wheel always slides without rolling.

Answer: A, B, C, D

Q.7 The electric field associated with an electromagnetic wave propagating in a dielectric medium is given by $\vec{E} = 30(2\hat{x} + \hat{y})\sin\left[2\pi\left(5 \times 10^{14}t - \frac{10^7}{3}z\right)\right]$ V m⁻¹. Which of the following option(s) is(are) correct?

[Given: The speed of light in vacuum, $c = 3 \times 10^8$ m s⁻¹]

(A) $B_x = -2 \times 10^{-7} \sin\left[2\pi\left(5 \times 10^{14}t - \frac{10^7}{3}z\right)\right]$ Wb m⁻².

(B) $B_y = 2 \times 10^{-7} \sin\left[2\pi\left(5 \times 10^{14}t - \frac{10^7}{3}z\right)\right]$ Wb m⁻².

(C) The wave is polarized in the xy -plane with polarization angle 30° with respect to the x -axis.

(D) The refractive index of the medium is 2.

Answer: A, D

SECTION 3 (Maximum Marks: 24)

- This section contains **SIX (06)** questions.
- The answer to each question is a **NON-NEGATIVE INTEGER**.
- For each question, enter the correct integer corresponding to the answer using the mouse and the on-screen virtual numeric keypad in the place designated to enter the answer.
- Answer to each question will be evaluated according to the following marking scheme:
Full Marks : +4 If **ONLY** the correct integer is entered;
Zero Marks : 0 In all other cases.

Q.8 A thin circular coin of mass 5 gm and radius $\frac{4}{3}$ cm is initially in a horizontal xy -plane. The coin is tossed vertically up ($+z$ direction) by applying an impulse of $\sqrt{\frac{\pi}{2}} \times 10^{-2}$ N-s at a distance $\frac{2}{3}$ cm from its center. The coin spins about its diameter and moves along the $+z$ direction. By the time the coin reaches back to its initial position, it completes n rotations. The value of n is 30.

[Given: The acceleration due to gravity $g = 10 \text{ m s}^{-2}$]

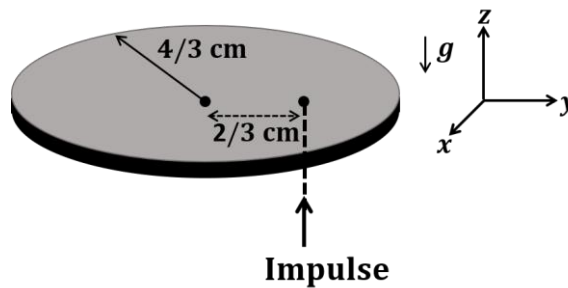

Q.9 A rectangular conducting loop of length 4 cm and width 2 cm is in the xy -plane, as shown in the figure. It is being moved away from a thin and long conducting wire along the direction $\frac{\sqrt{3}}{2} \hat{x} + \frac{1}{2} \hat{y}$ with a constant speed v . The wire is carrying a steady current $I = 10 \text{ A}$ in the positive x -direction. A current of $10 \mu\text{A}$ flows through the loop when it is at a distance $d = 4 \text{ cm}$ from the wire. If the resistance of the loop is 0.1Ω , then the value of v is 4 m s^{-1} .

[Given: The permeability of free space $\mu_0 = 4\pi \times 10^{-7} \text{ N A}^{-2}$]

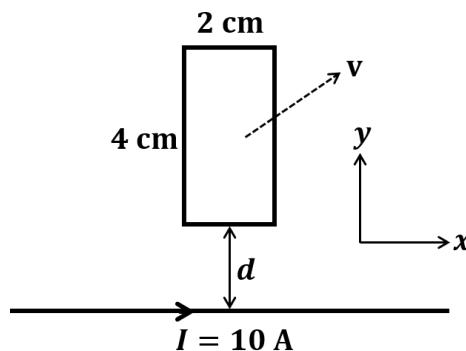

Q.10 A string of length 1 m and mass 2×10^{-5} kg is under tension T . When the string vibrates, two successive harmonics are found to occur at frequencies 750 Hz and 1000 Hz. The value of tension T is 5 Newton.

Q.11 An incompressible liquid is kept in a container having a weightless piston with a hole. A capillary tube of inner radius 0.1 mm is dipped vertically into the liquid through the airtight piston hole, as shown in the figure. The air in the container is isothermally compressed from its original volume V_0 to $\frac{100}{101}V_0$ with the movable piston. Considering air as an ideal gas, the height (h) of the liquid column in the capillary above the liquid level in cm is 25.

[Given: Surface tension of the liquid is 0.075 N m^{-1} , atmospheric pressure is 10^5 N m^{-2} , acceleration due to gravity (g) is 10 m s^{-2} , density of the liquid is 10^3 kg m^{-3} and contact angle of capillary surface with the liquid is zero]

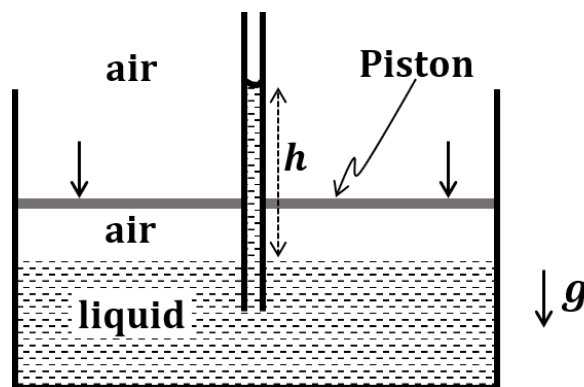

Q.12 In a radioactive decay process, the activity is defined as $A = -\frac{dN}{dt}$, where $N(t)$ is the number of radioactive nuclei at time t . Two radioactive sources, S_1 and S_2 have same activity at time $t = 0$. At a later time, the activities of S_1 and S_2 are A_1 and A_2 , respectively. When S_1 and S_2 have just completed their 3rd and 7th half-lives, respectively, the ratio A_1/A_2 is 16.

Q.13 One mole of an ideal gas undergoes two different cyclic processes I and II, as shown in the P - V diagrams below. In cycle I, processes a, b, c and d are isobaric, isothermal, isobaric and isochoric, respectively. In cycle II, processes a', b', c' and d' are isothermal, isochoric, isobaric and isochoric, respectively. The total work done during cycle I is W_I and that during cycle II is W_{II} . The ratio W_I/W_{II} is 2.

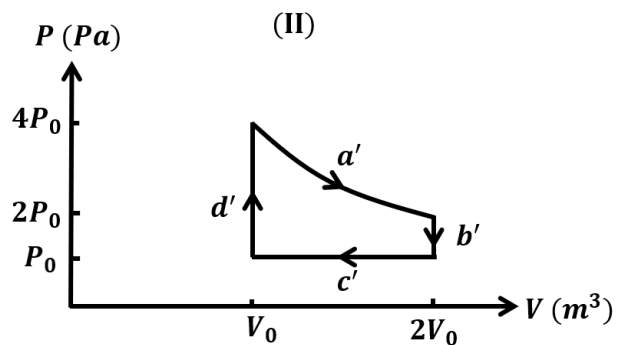
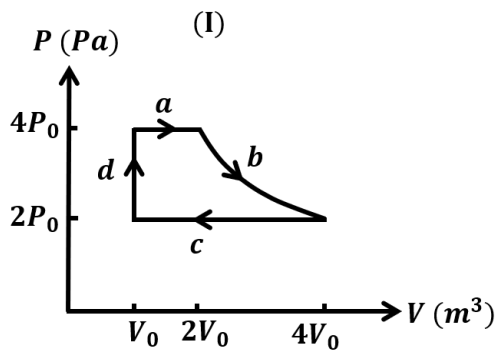

SECTION 4 (Maximum Marks: 12)

- This section contains **TWO (02)** paragraphs.
- Based on each paragraph, there are **TWO (02)** questions.
- The answer to each question is a **NUMERICAL VALUE**.
- For each question, enter the correct numerical value of the answer using the mouse and the on-screen virtual numeric keypad in the place designated to enter the answer.
- If the numerical value has more than two decimal places, **truncate/round-off** the value to **TWO** decimal places.
- Answer to each question will be evaluated according to the following marking scheme:

Full Marks : +3 If **ONLY** the correct numerical value is entered in the designated place;

Zero Marks : 0 In all other cases.

PARAGRAPH I

S_1 and S_2 are two identical sound sources of frequency 656 Hz. The source S_1 is located at O and S_2 moves anti-clockwise with a uniform speed $4\sqrt{2} \text{ m s}^{-1}$ on a circular path around O , as shown in the figure. There are three points P , Q and R on this path such that P and R are diametrically opposite while Q is equidistant from them. A sound detector is placed at point P . The source S_1 can move along direction OP .

[Given: The speed of sound in air is 324 m s^{-1}]

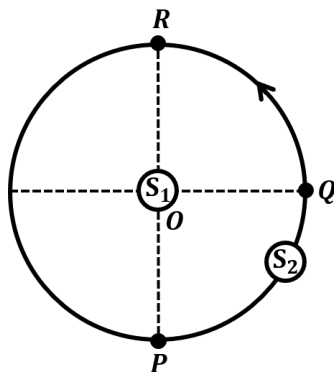

- Q.14 When only S_2 is emitting sound and it is at Q , the frequency of sound measured by the detector in Hz is 648.00. Range (648.00 to 648.00)

PARAGRAPH I

S_1 and S_2 are two identical sound sources of frequency 656 Hz. The source S_1 is located at O and S_2 moves anti-clockwise with a uniform speed $4\sqrt{2} \text{ m s}^{-1}$ on a circular path around O , as shown in the figure. There are three points P , Q and R on this path such that P and R are diametrically opposite while Q is equidistant from them. A sound detector is placed at point P . The source S_1 can move along direction OP .

[Given: The speed of sound in air is 324 m s^{-1}]

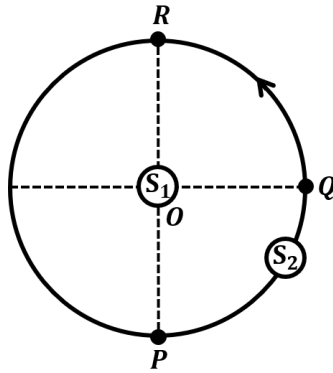

- Q.15 Consider both sources emitting sound. When S_2 is at R and S_1 approaches the detector with a speed 4 m s^{-1} , the beat frequency measured by the detector is 8.20 Hz. Range (8.00 to 8.40)
-

PARAGRAPH II

A cylindrical furnace has height (H) and diameter (D) both 1 m. It is maintained at temperature 360 K. The air gets heated inside the furnace at constant pressure P_a and its temperature becomes $T = 360$ K. The hot air with density ρ rises up a vertical chimney of diameter $d = 0.1$ m and height $h = 9$ m above the furnace and exits the chimney (see the figure). As a result, atmospheric air of density $\rho_a = 1.2$ kg m⁻³, pressure P_a and temperature $T_a = 300$ K enters the furnace. Assume air as an ideal gas, neglect the variations in ρ and T inside the chimney and the furnace. Also ignore the viscous effects.

[Given: The acceleration due to gravity $g = 10$ m s⁻² and $\pi = 3.14$]

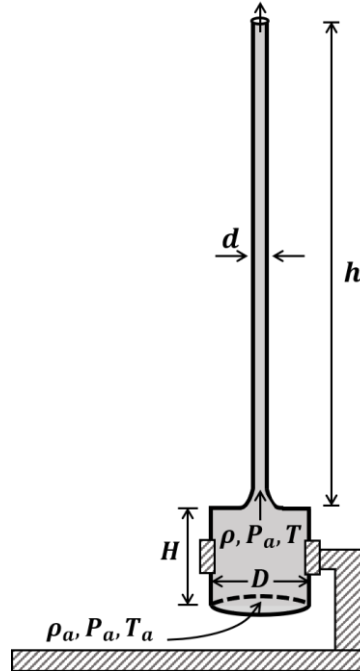

- Q.16 Considering the air flow to be streamline, the steady mass flow rate of air exiting the chimney is _____ gm s⁻¹.

Question Dropped
Marks for All

PARAGRAPH II

A cylindrical furnace has height (H) and diameter (D) both 1 m. It is maintained at temperature 360 K. The air gets heated inside the furnace at constant pressure P_a and its temperature becomes $T = 360$ K. The hot air with density ρ rises up a vertical chimney of diameter $d = 0.1$ m and height $h = 9$ m above the furnace and exits the chimney (see the figure). As a result, atmospheric air of density $\rho_a = 1.2 \text{ kg m}^{-3}$, pressure P_a and temperature $T_a = 300$ K enters the furnace. Assume air as an ideal gas, neglect the variations in ρ and T inside the chimney and the furnace. Also ignore the viscous effects.

[Given: The acceleration due to gravity $g = 10 \text{ m s}^{-2}$ and $\pi = 3.14$]

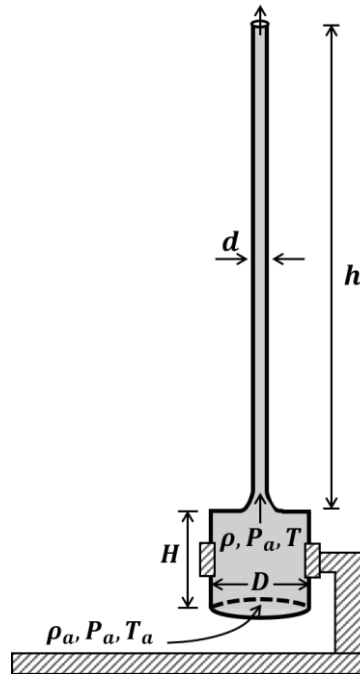

- Q.17 When the chimney is closed using a cap at the top, a pressure difference ΔP develops between the top and the bottom surfaces of the cap. If the changes in the temperature and density of the hot air, due to the stoppage of air flow, are negligible then the value of ΔP is _____ N m^{-2} .

END OF THE QUESTION PAPER

SECTION 1 (Maximum Marks: 12)

- This section contains **FOUR (04)** questions.
- Each question has **FOUR** options (A), (B), (C) and (D). **ONLY ONE** of these four options is the correct answer.
- For each question, choose the option corresponding to the correct answer.
- Answer to each question will be evaluated according to the following marking scheme:
Full Marks : +3 If **ONLY** the correct option is chosen;
Zero Marks : 0 If none of the options is chosen (i.e. the question is unanswered);
Negative Marks : -1 In all other cases.

Q.1 The correct molecular orbital diagram for F_2 molecule in the ground state is

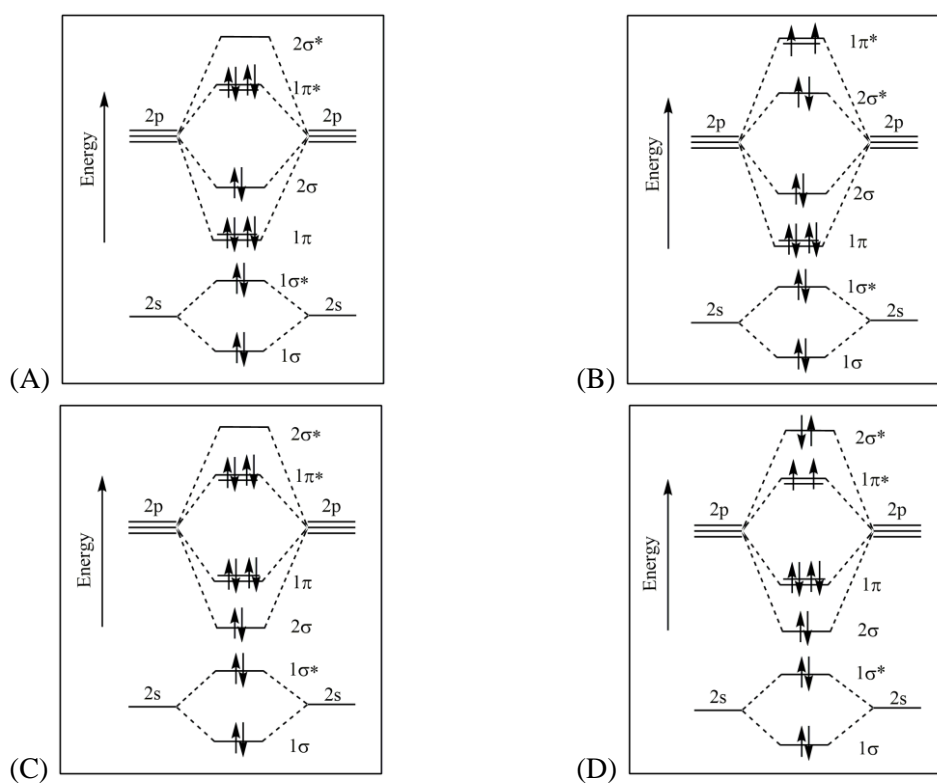

Answer: C

Q.2 Consider the following statements related to colloids.

- (I) Lyophobic colloids are **not** formed by simple mixing of dispersed phase and dispersion medium.
 (II) For emulsions, both the dispersed phase and the dispersion medium are liquid.
 (III) Micelles are produced by dissolving a surfactant in any solvent at any temperature.
 (IV) Tyndall effect can be observed from a colloidal solution with dispersed phase having the same refractive index as that of the dispersion medium.

The option with the correct set of statements is

- (A) (I) and (II)
 (B) (II) and (III)
 (C) (III) and (IV)
 (D) (II) and (IV)

Answer: A

Q.3 In the following reactions, **P**, **Q**, **R**, and **S** are the major products.

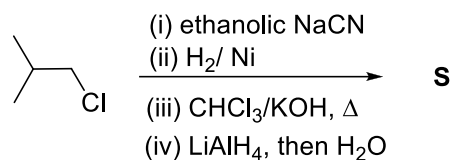
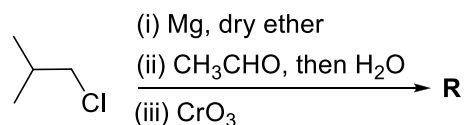
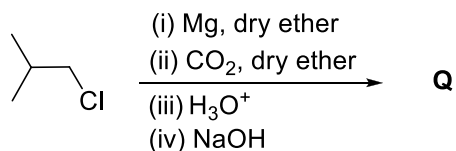
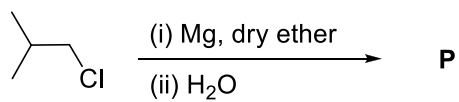

The correct statement about **P**, **Q**, **R**, and **S** is

- (A) **P** is a primary alcohol with four carbons.
 (B) **Q** undergoes Kolbe's electrolysis to give an eight-carbon product.
 (C) **R** has six carbons and it undergoes Cannizzaro reaction.
 (D) **S** is a primary amine with six carbons.

Answer: B

Q.4 A disaccharide **X** cannot be oxidised by bromine water. The acid hydrolysis of **X** leads to a laevorotatory solution. The disaccharide **X** is

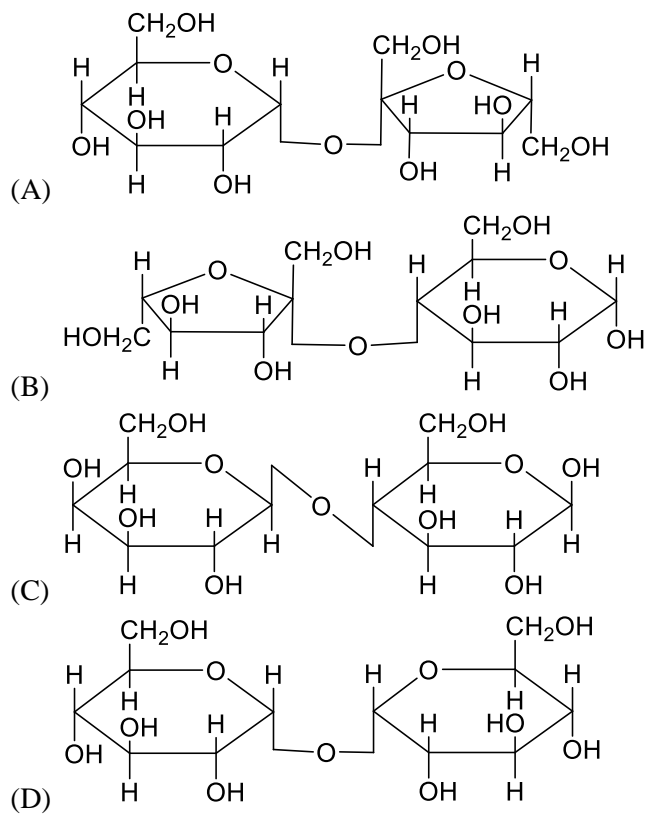

Answer: A

Q.6 Atoms of metals x, y, and z form face-centred cubic (fcc) unit cell of edge length L_x , body-centred cubic (bcc) unit cell of edge length L_y , and simple cubic unit cell of edge length L_z , respectively.

If $r_z = \frac{\sqrt{3}}{2} r_y$; $r_y = \frac{8}{\sqrt{3}} r_x$; $M_z = \frac{3}{2} M_y$ and $M_z = 3M_x$, then the correct statement(s) is(are)

[Given: M_x , M_y , and M_z are molar masses of metals x, y, and z, respectively.

r_x , r_y , and r_z are atomic radii of metals x, y, and z, respectively.]

(A) Packing efficiency of unit cell of x > Packing efficiency of unit cell of y > Packing efficiency of unit cell of z

(B) $L_y > L_z$

(C) $L_x > L_y$

(D) Density of x > Density of y

Answer: A, B, D

Q.7 In the following reactions, **P**, **Q**, **R**, and **S** are the major products.

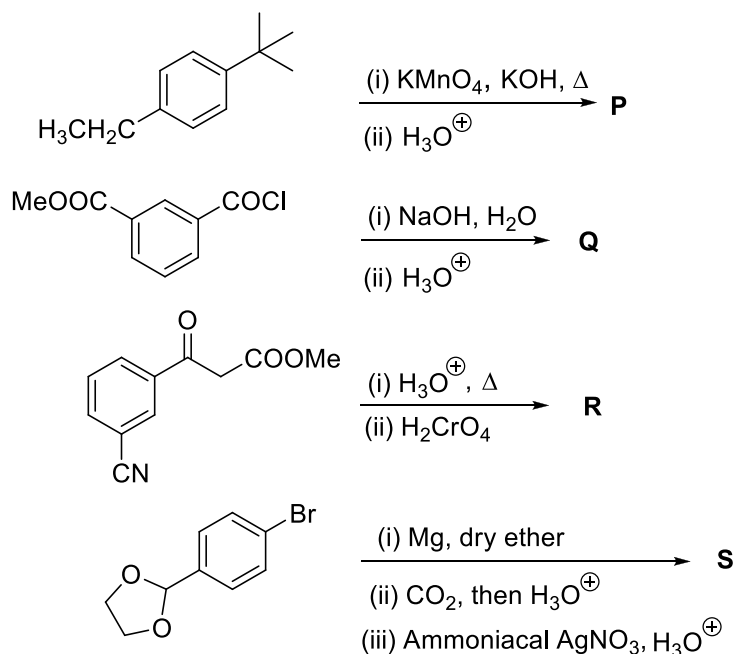

The correct statement(s) about **P**, **Q**, **R**, and **S** is(are)

(A) **P** and **Q** are monomers of polymers dacron and glyptal, respectively.

(B) **P**, **Q**, and **R** are dicarboxylic acids.

(C) Compounds **Q** and **R** are the same.

(D) **R** does **not** undergo aldol condensation and **S** does **not** undergo Cannizzaro reaction.

Answer: C, D

SECTION 3 (Maximum Marks: 24)

- This section contains **SIX (06)** questions.
- The answer to each question is a **NON-NEGATIVE INTEGER**.
- For each question, enter the correct integer corresponding to the answer using the mouse and the on-screen virtual numeric keypad in the place designated to enter the answer.
- Answer to each question will be evaluated according to the following marking scheme:
Full Marks : +4 If **ONLY** the correct integer is entered;
Zero Marks : 0 In all other cases.

Q.8 H₂S (5 moles) reacts completely with acidified aqueous potassium permanganate solution. In this reaction, the number of moles of water produced is **x**, and the number of moles of electrons involved is **y**. The value of (**x** + **y**) is 18.

Q.9 Among [I₃]⁺, [SiO₄]⁴⁻, SO₂Cl₂, XeF₂, SF₄, ClF₃, Ni(CO)₄, XeO₂F₂, [PtCl₄]²⁻, XeF₄, and SOCl₂, the total number of species having sp³ hybridised central atom is 5.

Q.10 Consider the following molecules: Br₃O₈, F₂O, H₂S₄O₆, H₂S₅O₆, and C₃O₂.
Count the number of atoms existing in their zero oxidation state in each molecule.
Their sum is 6.

Q.11 For He⁺, a transition takes place from the orbit of radius 105.8 pm to the orbit of radius 26.45 pm.
The wavelength (in nm) of the emitted photon during the transition is 30.

[Use:

Bohr radius, a = 52.9 pm

Rydberg constant, $R_H = 2.2 \times 10^{-18}$ J

Planck's constant, $h = 6.6 \times 10^{-34}$ J s

Speed of light, $c = 3 \times 10^8$ m s⁻¹]

Q.12 50 mL of 0.2 molal urea solution (density = 1.012 g mL^{-1} at 300 K) is mixed with 250 mL of a solution containing 0.06 g of urea. Both the solutions were prepared in the same solvent. The osmotic pressure (in Torr) of the resulting solution at 300 K is [682](#).

[Use: Molar mass of urea = 60 g mol^{-1} ; gas constant, $R = 62 \text{ L Torr K}^{-1} \text{ mol}^{-1}$;
Assume, $\Delta_{\text{mix}}H = 0$, $\Delta_{\text{mix}}V = 0$]

Q.13 The reaction of 4-methyloct-1-ene (**P**, 2.52 g) with HBr in the presence of $(\text{C}_6\text{H}_5\text{CO})_2\text{O}_2$ gives two isomeric bromides in a 9 : 1 ratio, with a combined yield of 50%. Of these, the entire amount of the primary alkyl bromide was reacted with an appropriate amount of diethylamine followed by treatment with aq. K_2CO_3 to give a non-ionic product **S** in 100% yield.

The mass (in mg) of **S** obtained is [1791](#).

[Use molar mass (in g mol^{-1}): H = 1, C = 12, N = 14, Br = 80]

SECTION 4 (Maximum Marks: 12)

- This section contains **TWO (02)** paragraphs.
- Based on each paragraph, there are **TWO (02)** questions.
- The answer to each question is a **NUMERICAL VALUE**.
- For each question, enter the correct numerical value of the answer using the mouse and the on-screen virtual numeric keypad in the place designated to enter the answer.
- If the numerical value has more than two decimal places, **truncate/round-off** the value to **TWO** decimal places.
- Answer to each question will be evaluated according to the following marking scheme:
Full Marks : +3 If ONLY the correct numerical value is entered in the designated place;
Zero Marks : 0 In all other cases.

“PARAGRAPH I”

The entropy versus temperature plot for phases α and β at 1 bar pressure is given.
 S_T and S_0 are entropies of the phases at temperatures T and 0 K, respectively.

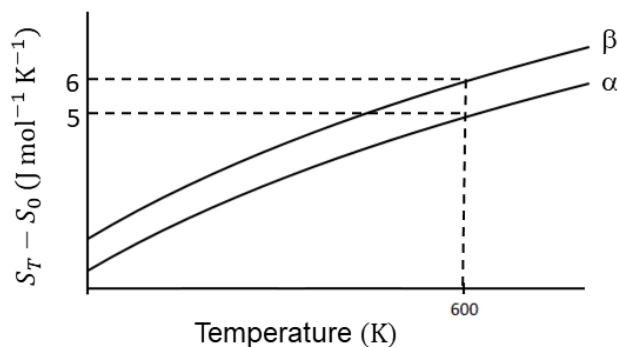

The transition temperature for α to β phase change is 600 K and $C_{p,\beta} - C_{p,\alpha} = 1 \text{ J mol}^{-1} \text{ K}^{-1}$. Assume $(C_{p,\beta} - C_{p,\alpha})$ is independent of temperature in the range of 200 to 700 K. $C_{p,\alpha}$ and $C_{p,\beta}$ are heat capacities of α and β phases, respectively.

Q.14 The value of entropy change, $S_\beta - S_\alpha$ (in $\text{J mol}^{-1} \text{ K}^{-1}$), at 300 K is 0.31. Range (0.30 to 0.32)

[Use: $\ln 2 = 0.69$

Given: $S_\beta - S_\alpha = 0$ at 0 K]

“PARAGRAPH I”

The entropy versus temperature plot for phases α and β at 1 bar pressure is given. S_T and S_0 are entropies of the phases at temperatures T and 0 K, respectively.

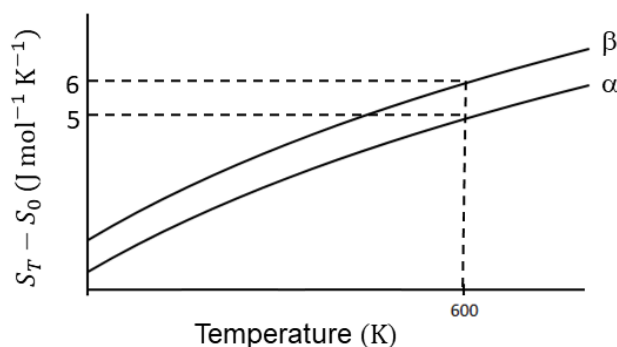

The transition temperature for α to β phase change is 600 K and $C_{p,\beta} - C_{p,\alpha} = 1 \text{ J mol}^{-1} \text{ K}^{-1}$. Assume $(C_{p,\beta} - C_{p,\alpha})$ is independent of temperature in the range of 200 to 700 K. $C_{p,\alpha}$ and $C_{p,\beta}$ are heat capacities of α and β phases, respectively.

Q.15 The value of enthalpy change, $H_\beta - H_\alpha$ (in J mol^{-1}), at 300 K is 300.00. Range (300.00 to 300.00)

“PARAGRAPH II”

A trinitro compound, 1,3,5-tris-(4-nitrophenyl)benzene, on complete reaction with an excess of Sn/HCl gives a major product, which on treatment with an excess of NaNO_2/HCl at 0°C provides **P** as the product. **P**, upon treatment with excess of H_2O at room temperature, gives the product **Q**. Bromination of **Q** in aqueous medium furnishes the product **R**. The compound **P** upon treatment with an excess of phenol under basic conditions gives the product **S**.

The molar mass difference between compounds **Q** and **R** is 474 g mol^{-1} and between compounds **P** and **S** is 172.5 g mol^{-1} .

Q.16 The number of heteroatoms present in one molecule of **R** is 9.00. Range (9.00 to 9.00)

[Use: Molar mass (in g mol^{-1}): H = 1, C = 12, N = 14, O = 16, Br = 80, Cl = 35.5
Atoms other than C and H are considered as heteroatoms]

“PARAGRAPH II”

A trinitro compound, 1,3,5-tris-(4-nitrophenyl)benzene, on complete reaction with an excess of Sn/HCl gives a major product, which on treatment with an excess of NaNO₂/HCl at 0 °C provides **P** as the product. **P**, upon treatment with excess of H₂O at room temperature, gives the product **Q**. Bromination of **Q** in aqueous medium furnishes the product **R**. The compound **P** upon treatment with an excess of phenol under basic conditions gives the product **S**.

The molar mass difference between compounds **Q** and **R** is 474 g mol⁻¹ and between compounds **P** and **S** is 172.5 g mol⁻¹.

Q.17 The total number of carbon atoms and heteroatoms present in one molecule of **S** is 51.00 .

Range (51.00 to 51.00)

[Use: Molar mass (in g mol⁻¹): H = 1, C = 12, N = 14, O = 16, Br = 80, Cl = 35.5

Atoms other than C and H are considered as heteroatoms]

END OF THE QUESTION PAPER